

SMARTY Saver

User Manual
Semi-automatic External Defibrillator
for Public Access

SMARTY[®]
SAVER

DOC ID: AMI-AED-IFU02-01-ENG
REV: 03.01

QUICK USE GUIDE



©by A.M.I. Italia S.r.l.

These instructions for use may not be reproduced - either as a whole or partially - without our consent, nor may they be transmitted, electronically stored or be translated in another language.

Breaches of this prohibition do not only violate our copyright, but also compromise the truthfulness and accuracy of the information contained in this manual.

These instructions for use are subject to amendment.

Notified Body Code “**CE 0051**”

"CE" is the abbreviation of "conformité européenne", which is the European conformity as per MDR 2017/745 for Medical Devices. 0051 is the Notified body number for IMQ ISTITUTO ITALIANO DEL MARCHIO DI QUALITÀ S.P.A.

A.M.I. Italia S.r.l.

REGISTERED OFFICE

Viale Campi Flegrei n.55, 80124 Napoli ITALIA

OPERATIVE SITES:

Via San Francesco a Patria SNC Località Ponte Riccio - Zona ASI-80014 Giugliano (NA) – Italia

Via Cupa Reginella, 15/A - 80010 Quarto (NA) Italia

Ph. +39 081 806 34 75 +39 081 806 05 74

Fax +39 081 876 47 69

e-mail: info@amiitalia.com

website: <http://www.amiitalia.com>

Printed in Italy

Table of Contents

1 Introduction..... 7

1.1 Preface..... 7

1.2 Intended Use..... 7

1.3 Intended Environment 7

1.4 User Qualification 7

1.5 Intended Patient Population 7

1.6 Use in conformity with the provisions 7

1.7 Warranty..... 8

1.8 Exclusion of liability 8

1.9 Clinical Benefits..... 8

1.10 Indications..... 9

1.11 Contraindications 9

1.12 Information on the version 9

1.13 Symbols used in the manual..... 9

1.14 Contact details of the manufacturer..... 10

2 Safety instructions..... 10

2.1 HAZARD statements 10

2.2 WARNINGS 11

2.3 Instructions for DISPOSAL 12

2.4 Classifications 13

3 Description of the device 14

3.1 Information on the defibrillator..... 14

3.2 Procedure for the activation of the defibrillator 14

4 Description of device details..... 15

4.1 General structure 15

4.2 Keys, icons and indicators..... 16

4.3 Device Packaging Contents..... 17

5 Details of Parts of SMARTY Saver 18

5.1 Batteries SMT-C14031 and SMT-C14033..... 18

5.1.1 Insertion and removal of the batteries 19

5.2 Defibrillation pads..... 19

5.2.1 Pre-connected universal defibrillation pads SMT-C2001 20

5.2.2 Pre-connected Face-to-Face universal defibrillation pads SMT-C2002 20

5.2.3 Placement of the defibrillation pads..... 21

5.2.4 Adult and Paediatric mode 21

5.3 µSD memory Card 22

5.4 SaverViewExpress 22

6 Self-test..... 23

6.1 ACTIVATION test..... 23

6.2 AUTOMATIC test 24

6.3 POWER ON test 24

6.4 Control LEDs 24

7	Defibrillation.....	25
7.1	“Chain of survival”	25
7.2	Switching SMARTY Saver on.....	25
7.3	Preparing the patient.....	26
7.4	Place the pads.....	26
7.5	Heartbeat analysis	27
7.6	Defibrillable rhythm.....	28
7.7	Change of rhythm.....	29
7.8	Non-defibrillable rhythm.....	29
7.9	Cardio-Pulmonary Resuscitation.....	29
8	Recording, displaying and storing the data	31
8.1	Files that can be stored.....	31
8.2	Storage of data on a PC.....	31
9	Possible Residual Risks and Remedies:	32
9.1	Final Residual Risk Status.....	39
10	Maintenance.....	40
10.1	Maintenance after use.....	40
10.2	Scheduled maintenance	40
10.3	Cleaning	41
10.4	Storage	41
10.5	Guide to identifying faults.....	42
10.6	Service.....	43
11	Technical specifications.....	43
11.1	Physical characteristics	43
11.2	Environmental requirements	43
11.3	Reference regulatory frameworks	44
11.4	Table of Alarms.....	46
11.5	Controls and indicators.....	46
11.6	Data memory	46
11.7	Defibrillator.....	47
11.8	Efficiency of the energy delivered	48
11.9	Patient analysis system.....	49
11.10	ECG Analysis operation.....	49
11.11	Defibrillator batteries	49
11.12	Internal back-up battery	50
11.13	Defibrillation pads.....	50
11.14	Timing of Shock cycles.....	50
11.15	Hardware Requirements	51
11.16	Cyber Security Safety applicability.....	51
11.17	Software Requirements	52
12	Compliance with electromagnetic emission standards.....	53
12.1	Guidelines and manufacturer declaration – Electromagnetic emissions	53
12.2	Guidelines and manufacturer declaration - Electromagnetic immunity	53
12.3	Recommended separation distances between portable and mobile RF communication devices and the SMARTY Saver device.....	55
13	Symbols	56

14	SMARTY Saver Series defibrillator warranty	58
15	Declaration of Medical Substances	59
16	Additional Information	59
16.1	Incident Reporting	59
16.2	Information Available to The User	59
16.3	Availability of SSCP	59

1 Introduction

1.1 Preface

Thank you for choosing the defibrillator manufactured by A.M.I. Italia S.r.l., **SMARTY Saver** model.

In order to use the device correctly, you must read this user manual carefully before use. This user manual contains the instructions for the use of **SMARTY Saver** in compliance with its functionality and purpose. For an error-free operation, it is fundamental that you comply with the requirements of this manual, in order to guarantee the safety of the patient, of the rescuer and that of third parties.

This manual forms an integral part of the defibrillator and must always be kept in close proximity to the defibrillator, so that it may be easily consulted whenever needed.

Note: In order to guarantee the correct and fast traceability of the product and to receive information regarding all implemented updates, the user is requested to register the device at the appropriate section of the A.M.I. Italia S.r.l. website, www.amiitalia.com

1.2 Intended Use

The intended use of External Cardiac Defibrillator is the detection of the electrocardiogram with consequent cardiac defibrillation via electric shock, in the event that ventricular tachycardia or ventricular fibrillation is detected. They are intended and used to stop ventricular fibrillation and pulseless ventricular tachycardia.

1.3 Intended Environment

This Device to be used under controlled environment. The Storage/Transport and Operation Temperature limits mentioned in “Section 11” Technical Specifications

1.4 User Qualification

Regulations governing requirements regarding use and training for AED devices, differ from country to country. Strictly follow the local laws and regulations for the use of automated external defibrillators.

In any case, it is recommended to attend a BLS (Basic Life Support & Defibrillation) training course in order to be able to intervene effectively in an emergency both in using the defibrillator and in performing CPR.

Defibrillators can be used both in healthcare and emergency environments (ambulances, emergency rooms, etc.) and in non-healthcare settings (public or private places).

1.5 Intended Patient Population

The devices are used on adult or paediatric patients (children under 8 years of age and weighing < 25Kg) suffering from ventricular fibrillation or ventricular tachycardia, victims of sudden cardiac arrest. Patients in cardiac arrest are unresponsive and do not breathe normally. The device can only be used if the patient: is unconscious, not breathing and has no heartbeat.

In agreement with the international guidelines for resuscitation (AHA, ERC), the defibrillation procedures in the framework of a correct and efficient cardio-pulmonary resuscitation treatment are appropriate for patients of any age, following the recommendations of the above said guidelines concerning the energy level to be delivered to adult or paediatric patients. Neither contraindication nor energy limitation are envisaged for particular classes of patients like e.g. pregnant women, breastfeeding women.

1.6 Use in conformity with the provisions

The **SMARTY Saver Series** devices can be used only if the conditions indicated in this user manual are complied with. All uses that differ from the intended use shall be understood not to comply with the provisions and may cause harm/damage to persons and/or property; in such case, A.M.I. Italia S.r.l. hereby declines all liability.

Please note:

- The user is responsible for checking the device for broken/worn cables and to inform the manufacturer for service/repair/replacement.
- Before and after use of every patient, the device should be cleaned as per the cleaning procedure specified in this manual.

- The product service life is 10 years.
- A defective product should not be used.
- Parts that are broken, missing, plainly worn, distorted or contaminated should be replaced immediately.
- The manufacturer is not responsible for any malfunction resulting from not following user manual instruction, improper use, faulty maintenance, improper repair, damage, or alteration by anyone other than A.M.I. Italia S.r.l..
- The device parameters to be modified only by authorized persons like doctors/technicians by entering valid credentials. Avoid unauthorized persons accessing the device to avoid loss of parameter setting.
- Neither this product nor any of its parts should be repaired in any manner other than in accordance with written instructions provided by A.M.I. Italia S.r.l..
- The product must not be altered without the prior written approval of A.M.I. Italia S.r.l. Quality Assurance Department.
- Use only Power source indicated on the label and “Section 11” of this manual.

1.7 Warranty

The **SMARTY Saver Series** devices are under warranty for 5 (five)* years.

The non-rechargeable batteries SMT-C14031 and SMT-C14033 are respectively under warranty for 3 (three)* and for 4 (four)* years in Stand-by mode (assuming a battery activation test, daily self-tests and without the AED ever being switched on).

This information refers to new batteries, that are fully charged and kept at a temperature of 20°C and 45% humidity.

**For more information, please see paragraph 14 “Warranty contract for SMARTY Saver series defibrillators”*

1.8 Exclusion of liability

Liability rights in case of harm/damage to persons or to property shall be excluded, if attributable to one of the causes below:

- Using the device for uses other than its intended use.
- Using and maintaining the device inappropriately.
- Using the device and/or its accessories when they are visibly or partially damaged.
- Failing to comply with the instructions of the user manual concerning the precautions, use, maintenance and repair of the device.
- Using non-original accessories and spare parts and/or of accessories and spare parts that are not approved by the manufacturer.
- Performing arbitrary operations, repairs or modifications of the device.
- Arbitrarily exceeding the performance limits.
- Failing to supervise the parts that are subject to wear and tear.

1.9 Clinical Benefits

1. No risk of inappropriate shocks
2. Minimized risk of injury to patient and rescuer
3. No complications or adverse events
4. Excellent survival rate
5. High specificity and sensitivity
6. Easier to use and more appropriate for lay rescuer
7. Errors associated with AED use are rare
8. More accurate
9. Reduced size, weight, cost and maintenance
10. Better compliance with resuscitation protocols
11. AEDs are low-energy portable electronic devices designed to treat VF (Ventricular Fibrillation)
12. Improve survival in victims of sudden cardiac arrest & Increase survival in OHCA & to hospital discharge.
13. Easy to handle.
14. Effective in reducing the time to defibrillation.
15. Lifesaving potential of public access to defibrillation.
16. Safe and effective.
17. Reduced variability in time to deliver shocks.
18. High Sensitivity & Specificity.

19. No complications.
20. Delivers quick shocks

1.10 Indications

Defibrillator use is indicated to treat patients, both adults and paediatric, suffering from sudden cardiac arrest.

It can be used only if all of the following conditions are met:

- the patient is unconscious
- the patient is not breathing
- the patient has no heartbeat

1.11 Contraindications

The devices cannot be used if the patient:

- is conscious or
- has normal breathing or
- has a heartbeat.

1.12 Information on the version



This user manual has a version number; this varies each time the manual is updated due to changes in the device's operation or to the device itself. The contents of this user manual shall be subject to amendment without advance notice.

Version number: 03.01

Issue date: 20/12/2023

1.13 Symbols used in the manual

This user manual uses various symbols that indicate the various precautions for use:

SYMBOL	INDICATION	DESCRIPTION
	HAZARD	It signals an immediate risk to the safety of persons, which might result in death and damage to the device or its parts
	WARNING	It signals an unsafe situation or practice which might lead to serious injury to persons and damage to the device or its parts.

1.14 Contact details of the manufacturer

A.M.I. Italia S.r.l.
REGISTERED OFFICE
Viale Campi Flegrei n.55, 80124 Napoli ITALIA

PRODUCTION SITE ITALY

PRODUCTION, LABORATORIES, OFFICES

Via Cupa Reginella, 15/A 80010 Quarto (NA) ITALY
Ph. +39 081 806 0574 Fax. +39 081 876 4769

PRODUCTION SITE ITALY

PRODUCTION

Via San Francesco a Patria snc Località Ponte Riccio
Zona ASI 80014 Giugliano in Campania (NA) ITALY
Ph. +39 081 3797567

ASSISTANCE REQUEST

email: info@amiitalia.com

Ph: +39 081 806 05 74

Website: www.amiitalia.com

DATA OF THE NOTIFIED BODY

Notified Body

Name: IMQ ISTITUTO ITALIANO DEL MARCHIO DI QUALITÀ S.P.A.

Address: Via Quintiliano 43, 20138 Milano Italy - Tel: +39 02 50731

Notified Body Number: 0051

2 Safety instructions

For the correct use of a **SMARTY Saver Series** defibrillator, the users must be aware of the safety factors listed below.

We recommend that you read them carefully.

The **SMARTY Saver Series** defibrillators and their accessories comply with the rules and regulations on safety that are currently in force and with the provisions of the directives on medical products.

The device and its accessories must be deemed to be safe in the case of application in compliance with the provisions and if the descriptions and instructions listed in this user manual are complied with.

Below please find the main precautions for the correct and safe use of the defibrillator, divided for easier consultation in hazard statements, warnings and instructions for disposal.

2.1 **HAZARD** statements



- Use **SMARTY Saver** in compliance with what is laid down in this user manual. Read these instructions and, in particular, the safety instructions carefully.
- In compliance with IEC standards, use of the **SMARTY Saver** device or of its accessories is not allowed in the presence of inflammable substances (gasoline or similar) or in an oxygen-rich atmosphere or an atmosphere rich in inflammable gases/vapours.
- Do not recharge the SMT-C14031 and SMT-C14033 single-use batteries: risk of explosion!
- Avoid contact of the batteries with open flames. Do not expose to fire.
- Do not cause a short-circuit of the battery terminals.
- In case of leakage of fluids or strange odours from the batteries, keep them away from fire to prevent the possible combustion of leaking electrolytes.
- Shock hazard. The device generates high voltage and hazardous current levels. Do not open **SMARTY Saver** do not remove the panels and do not attempt to repair it. **SMARTY Saver** does not contain components that can

be repaired by the users. In order to perform repairs, **SMARTY Saver** must be sent to an authorised technical support centre.

- Do not apply the defibrillation pads on the patient's chest if nitroglycerine plasters are present. Only place the electrodes once you have removed the plasters. Otherwise, there is a risk of explosion.
- Do not touch the patient and prevent third parties from coming into contact with the patient during the defibrillation shock. Avoid all contact between:
 - parts of the patient's body
 - conducting liquids (such as gel, blood, or saline solution)
 - metal objects near the patient (such as the bed frame or a stretching device) that may potentially act as conductors for the defibrillation current.
- Before using the device, make sure that the patient is safe; if necessary, move them carefully to a protected location, as set forth by the international guidelines AHA/ERC.
- Do not immerse any part of **SMARTY Saver** or its accessories in water or other liquids.
- Do not allow liquids to enter **SMARTY Saver** or its accessories. Avoid pouring liquids on the device and its accessories. Otherwise, damage may be caused or there may a risk of fire or shock. Do not sterilise **SMARTY Saver** and/or its accessories.

2.2 WARNINGS



- Avoid the formation of air bubbles between the skin and the defibrillation pads. The formation of air bubbles during defibrillation may cause severe burns to the patient's epidermis. To avoid the formation of air bubbles, make sure that the electrodes are in full contact with the skin. Do not use electrodes whose gel has dried out and check its expiry date before use.
- Do not delay treatment in case of patients with an implanted pacemaker and perform an attempt at defibrillation if the patient has lost consciousness and is not breathing or is not breathing normally.
- Do not apply the defibrillation electrodes directly on an implanted pacemaker, to avoid possible device interpretation errors and to avoid damaging the pacemaker with the defibrillation pulse. During the application of the electrodes:
 - Do not apply the electrodes directly on an implanted device.
 - Apply the electrodes at least 2.54 cm (1 inch) from any implanted device.
- If a pacemaker is present, the defibrillators of the **SMARTY Saver** series will, in any case, make it possible to release the shock, unless, although they envisage a treatment of the ECG signal such as to guarantee an accurate rejection of the artefacts, the interference of the pacemaker is such (e.g., due to the electrodes being placed in a way that does not comply with the warning indicated) as to alter the ECG signal and not allow the shock.
- RF (radiofrequency) interference from devices such as mobile phones and radio two-way transmitters, can cause **SMARTY Saver** to malfunction. **SMARTY Saver** must be kept at least 2 metres away from such RF devices, as indicated in the IEC/EN 61000-4-3 standards. Keep at sufficient distance from other therapeutic and diagnostic sources of energy (e.g., diathermy, high-frequency surgery, magnetic tomography).
- Before using the device, make sure that it is not obviously damaged.
- Do not use universal defibrillation PADS SMT-C2001 and face to face PADS SMT-C2002 in paediatric mode on adult patients (older than 8 and weighing more than 25 kg). In fact, in paediatric mode, **SMARTY Saver** automatically reduces the maximum energy that can be delivered to 50J.
- Place the patient cables in such a way as to reduce the possibility of them getting entangled in or strangling the patient.
- In a domestic environment, keep the defibrillator away from the reach of children and pets.
- Disconnect the patient from equipment that is sensitive to high voltage pulses, or equipment that is not defibrillator-proof, before delivering the shock.
- Do not allow the defibrillation electrodes to touch or to come into contact with ECG electrodes, pads, transdermal plasters, etc. Otherwise, the formation of electric arcs and burns to the patient could be caused during defibrillation; the electricity may even be dispersed.
- Place the defibrillation pads as indicated in this user manual and on the packaging.
- Do not use the defibrillation pads if the gel has come away from the support or if it appears torn, divided or dry.
- If damage has been found, in no case should you switch **SMARTY Saver** on.
- Before using the device, remove metal objects from the patient's body (including necklaces or bracelets, etc.).
- Do not use defibrillation pads other than those supplied by the manufacturer. Otherwise, the defibrillator may perform false interpretations.
- Do not use the defibrillation pads if they are damaged, even partly.
- Do not touch the patient or the defibrillation pads during the automatic analysis of the heartbeat.
- Moving or transporting the patient during the analysis of the heartbeat by the device may lead to a wrong or untimely diagnosis. Reduce movements to a minimum while the heartbeat is being analysed. If the device is

- used in a moving ambulance, stop the vehicle and only start driving after the shock has been delivered.
- It is recommended to attend a BLS (Basic Life Support and Defibrillation) training course to intervene effectively in an emergency both in using the defibrillator and in performing CPR.
 - Avoid using the universal defibrillation PADS SMT-C2001 and face to face PADS SMT-C2002 in adult mode on children (aged 1-8 or weighing 10-25 kg). In fact, in adult mode, **SMARTY Saver** does not automatically reduce the maximum energy that can be delivered to 50J and may, therefore, become hazardous for the paediatric patient.
 - If needed, before applying the defibrillation pads dry the patient's chest and remove excess hair.
 - Do not subject **SMARTY Saver**, its accessories and/or its parts to falls and/or strong impacts.
 - Do not use damaged accessories and/or parts; otherwise, the device may be caused to malfunction.
 - Use solely original accessories and/or spare parts.
 - Avoid handling the device, its accessories or its parts too aggressively to avoid possible damage. Inspect the entire system regularly.
 - Sanitise the device in compliance with the rules of paragraph 10.3, and, in any case, always make sure that the device is switched off, without battery and with the pads disconnected.
 - The defibrillation pads are single-use, to be used on just one patient. Do not reuse the defibrillation pads; throw them away after use and replace them with a new pair.
 - The defibrillation pads are not sterile or sterilisable.
 - The intense or prolonged administration of cardiopulmonary resuscitation with the defibrillation electrodes applied to the patient can damage the electrodes. Replace them if they are damaged due to use or handling.
 - Inappropriate maintenance may damage **SMARTY Saver** or cause it to malfunction. Comply with what is described in this User Manual.
 - Use original non-rechargeable SMT-C14031 or SMT-C14033 batteries from A.M.I. Italia S.r.l. within the duration indicated in this manual.
 - Remove the batteries from the device only if it has been off for at least 5 seconds. Otherwise, the device and the batteries may be damaged.
 - **SMARTY Saver**, its parts and accessories are manufactured non-sterile and non-sterilisable.
 - Do not expose **SMARTY Saver**, its parts or accessories to direct light or high temperatures.
 - All products, product data and specifications are subject to modification to improve their reliability, functionality, design or other aspects.

2.3 Instructions for **DISPOSAL**



- **SMARTY Saver**, its parts and accessories must not be disposed of with other household waste within the European Union. To prevent possible harm to the environment or to persons' health caused by incorrect disposal of waste, recycle this product responsibly, also to promote a sustainable use of resources. In order to discard the used product, go to the appropriate waste collection centre or take it to the local distributor. It will then be possible to recycle the product with safety for the environment.

2.4 Classifications

UMDNS code	11132
GMDN code	11132
CND code	Z12030501
CIVAB [Biomedical Equipment Information and Assessment Centre] code	[T.B.D.]
Class in accordance with MDR 2017/745 of Annex VIII, Rule No.22	III
Type of protection from electric shock	Powered Internally
Type of patient insulation	BF
Degree of protection against penetration by liquids	IPx6
Degree of protection against penetration by dust	IP5x
Degree of safety in the presence of inflammable anaesthetic mixtures with air, oxygen or nitrous oxide	Not protected
Sterilisation or disinfection method suggested by the supplier	See Paragraph 10.3
Operation mode	Continuous operation

3 Description of the device

3.1 Information on the defibrillator

SMARTY Saver is known as an **AED**, i.e., **Automatic External Defibrillator**.

Its purpose is to cope with the emergency of a patient suffering from sudden cardiac arrest and to assist in Cardio Pulmonary Resuscitation (CPR).

For qualification of the intended user of the defibrillator, refer to section 1.4

The device is able to automatically detect and analyse the patient's rhythm, and to deliver one or more defibrillation shocks if it detects a ventricular defibrillation or a ventricular tachycardia (monomorphic or polymorphic with >180 beats). The energy is delivered through a biphasic truncated exponential (BTE) electrical shock that can self-adapt to the patient's thoracic impedance.

SMARTY Saver is available in two versions:

- **SM1-B1001: SMARTY Saver** Semi-automatic. Maximum energy delivered 200J
- **SM2-B1002: SMARTY Saver** Automatic. Maximum energy delivered 200J

It is powered by the following non-rechargeable batteries:

- **SMT-C14031** (Standard)
- **SMT-C14033** (High Power).

The device makes it possible to register rescue data on an external μ SD Memory Card (optional) so that they can be displayed on a PC using a special software owned by A.M.I. Italia S.r.l. In stand-by mode (not in use but with the battery installed), the device performs daily self-tests to check its operating status, in order to guarantee ready use in case of emergency.

The keyboard of the device is equipped with two LEDs (red and green) that make it possible to ascertain the outcome of the operational tests and know the status of the device even if it is switched off (stand-by mode).

Note: In case of any product failure /any serious incident occurs in connection with the device, user shall inform the manufacturer and the competent authority of the member state.

3.2 Procedure for the activation of the defibrillator

Open the packaging and make sure that all materials supplied are intact, checking their expiry date (defibrillation pads) and storage conditions.

Connect the pads connector and the battery to the defibrillator and wait for the initial test to start; the device will ask you to push the shock button for the full check of the device.

If the activation test is successful, the device invites you to connect the plates to the patient. At this point, switch off the device, leave the pads and the battery connected and check that the green LED blinks every six seconds. Lastly, place the defibrillator back in a safe and accessible place, so that it is ready for use.

4 Description of device details

4.1 General structure

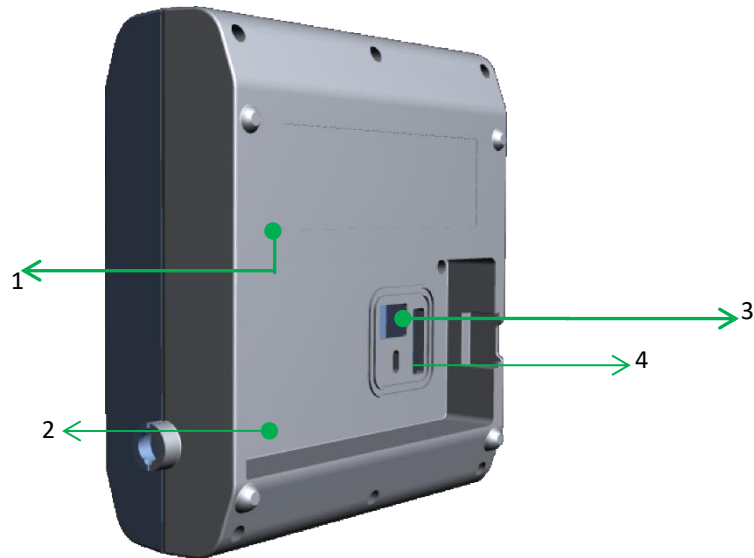

No.	Description
1	<i>SMARTY Saver</i> label
2	Battery compartment
3	μSD Memory Card compartment
4	USB-C port (for the exclusive use of A.M.I. Italia S.r.l.)
5	PADs connector
6	<i>SMARTY Saver</i> device microphone
7	<i>SMARTY Saver</i> logo
8	<i>SMARTY Saver</i> speaker
9	Keyboard with buttons and illuminated icons

4.2 Keys, icons and indicators

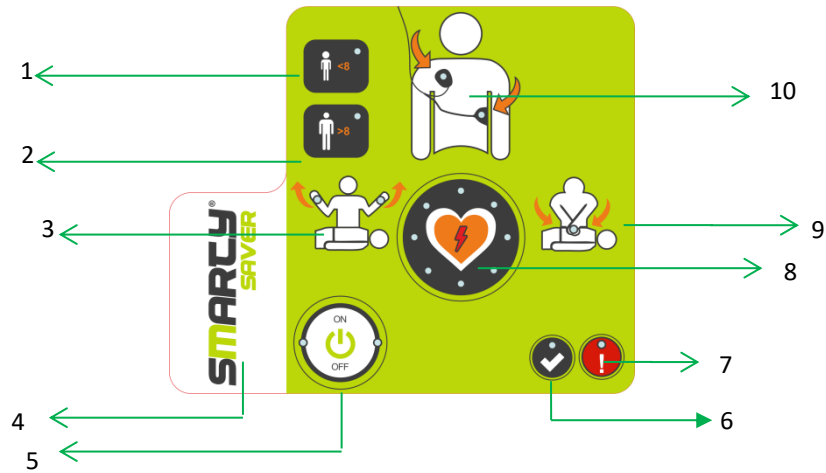

No.	Function	No.	Function
1	Paediatric Selection Button Selection of the paediatric patient type using universal pads	6	Green control LED In stand-by mode: correct operation status of the device
2	Adult Selection Button Selection of the adult patient type using universal pads	7	Red control LED In stand-by mode: device error status
3	“Do Not Touch” indicator Icon with lit illuminated LEDs: do not touch the patient	8	Shock button Delivery of the defibrillation shock
4	Product logo Device model	9	“CPR” indicator Start Cardio-Pulmonary Resuscitation
5	“ON/OFF” button Switch the device on/off	10	“Place pads” indicator Place the defibrillation pads.

4.3 Device Packaging Contents

The *SMARTY Saver* defibrillator is supplied with the following accessories & components:

#	Image	Quantity	Description
SM1-B1001		1 Unit	<i>SMARTY Saver</i> Semi-Automatic 200J
SMT-C2001		1 Pair	Pre-connected universal pads for adult and paediatric use (Class III device)
SMT-C14031		1 Unit	Battery
SMT-C1916		1 Unit	Carrying bag
SMT-C1077		1 Unit	User Guide

Below please find a list of accessories and components, that may be purchased separately:

#	Image	Quantity	Description
SMT-C14033		1 Unit	Non-rechargeable battery (High Power)
SMT-C2002	Front - Rear 	1 Pair	Pre-connected universal pads for paediatric and adult use Face-to-face (Class III device)
SAV-C0019		1 Unit	Saver View Express
SMT-C1907		1 Unit	µSD Card
SAV-C0027		1 Unit	Memory Card reader for PC

5 Details of Parts of SMARTY Saver

5.1 Batteries SMT-C14031 and SMT-C14033

The non-rechargeable battery is supplied with the AED, fully charged and ready for use. They were designed for long-lasting autonomy and to perform a high number of rescue cycles:

- **SMT-C14031:** approximately 200 full rescue cycles (shocks at 200J and CPR)
- **SMT-C14033 (High power):** approximately 350 full rescue cycles (shocks at 200J and CPR).

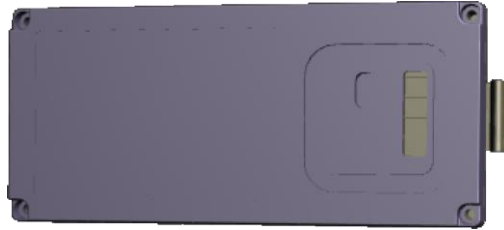

The estimated service life is approximately three (3) years for SMT-C14031 and four (4) years for SMT-C14033 from the installation of the AED and the first activation test, with the device in stand-by mode (i.e. no subsequent AED switch-on) with activity limited to daily self-tests.

If the battery level is low, the user will be informed with audio and/or visual signals depending on the operating mode of the device: audio and visual in operation mode, visual only in stand-by mode.

In detail:

- **WARNING:** Residual battery level equal to or lower than **5%**.
This audio warning will only be issued in operation mode.
Battery level at $\leq 5\%$ makes it possible to perform approximately 10 shocks and allows the device to operate in stand-by mode for about 40 days
- **ALARM:** Battery residual capacity level equal to or lower than **1%**
This alarm will be issued in both stand-by (only visual) and operation mode (audio and visual).
With the battery at $\leq 1\%$, makes it possible to perform approximately 5 shocks and allows the device to operate in stand-by mode for about 20 days
We do not recommend using the device in this condition and to replace the battery immediately

!!ATTENTION!!

In order to safeguard the duration of the battery and guarantee the automatic tests of the device, it is recommended, after installing the battery, not to remove it until you replace it.

The removal and subsequent reintroduction of the battery, in fact, results in a full test of the AED which significantly affects its longevity. In addition, if the battery is not connected correctly, it may be damaged.

5.1.1 Insertion and removal of the batteries

Below please find detailed instructions for the correct installation of the battery in the device *SMARTY Saver*.

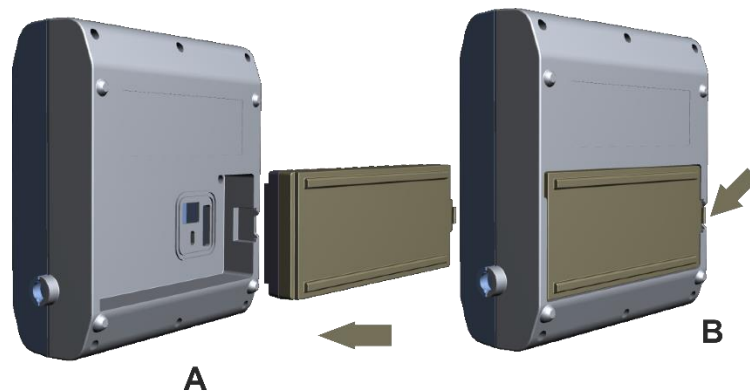

- Place the device as shown in figure (first on the left)
- Place the battery as shown in figure (central)
- Inserting it in the dedicated compartment, push the battery as shown in figure (last on the right)

Follow the instructions below to remove the battery from the device:

- Make sure the device is switched off.
- Pull on the tab on the side of the battery and take the battery out of the dedicated compartment as shown in figure (last on the right).

5.2 Defibrillation pads

SMARTY Saver is made to use two different types of universal defibrillation pads, to be used on adult and paediatric patients;

- **SMT-C2001:** Pre-connected universal defibrillation pads
- **SMT-C2002:** Pre-connected “face-to-face” universal defibrillation pads

Before to connect the patient to the defibrillator, depending on the patient to be treated, you must select on the keyboard of the *SMARTY Saver* device the type of patient (adult age >8 or weight >25 kg / paediatric age from 1 to 8 or weight <25 kg). The use of this type of pads is, in general, contraindicated in patients younger than 12 months and weighing less than 10 kg.

The pre-connected universal defibrillation pads are class III medical devices; the term “pre-connected” means that the cable and the connector are external to the sealed packaging, so that they can be pre-connected to the device, thus avoiding having to insert the connector during aid.

For more detailed information, please always refer to the related pads user manual and to the indications on the electrodes’ bag.

5.2.1 Pre-connected universal defibrillation pads SMT-C2001

The defibrillation pads SMT-C2001 are universal, single-use and pre-gelled. They are supplied in individual sealed packaging which mentions the expiry date (typically 30 months); on the indicated expiry date, the pads must be replaced, even if they have never been used.

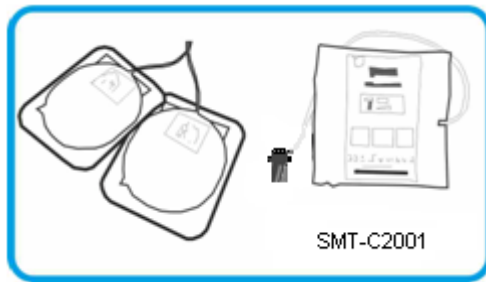

5.2.2 Pre-connected Face-to-Face universal defibrillation pads SMT-C2002

Face-to-Face universal defibrillation pads SMT-C2002 are universal, single-use and pre-gelled. The term “face-to-face” indicates that the plates are electrically paired so that the *SMARTY Saver* device can measure their effectiveness - based on the quality of the gel’s conductivity - and warn - using control LEDs - when it has declined.

This signal must result in the replacement of the pads.

After the expiry date mentioned on the packaging, it is recommended to replace the pads, regardless of the signal issued by the defibrillator

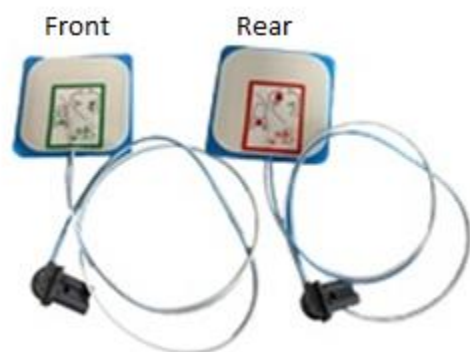
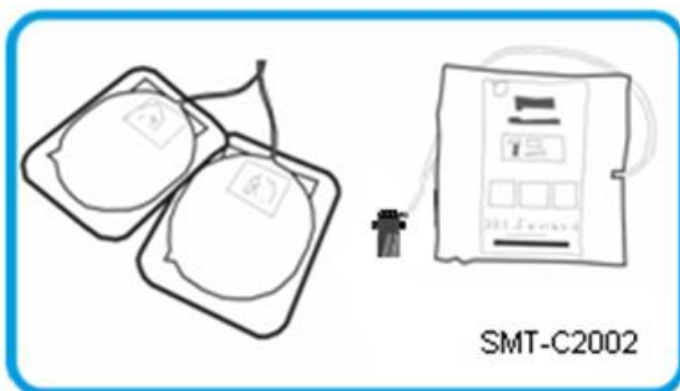

5.2.3 Placement of the defibrillation pads

The correct placement of the pads on the patient is essential for an effective analysis of the heartbeat and for the consequent delivery of the shock (if needed). Please always refer to the instructions on the packaging and to the specific user manual.

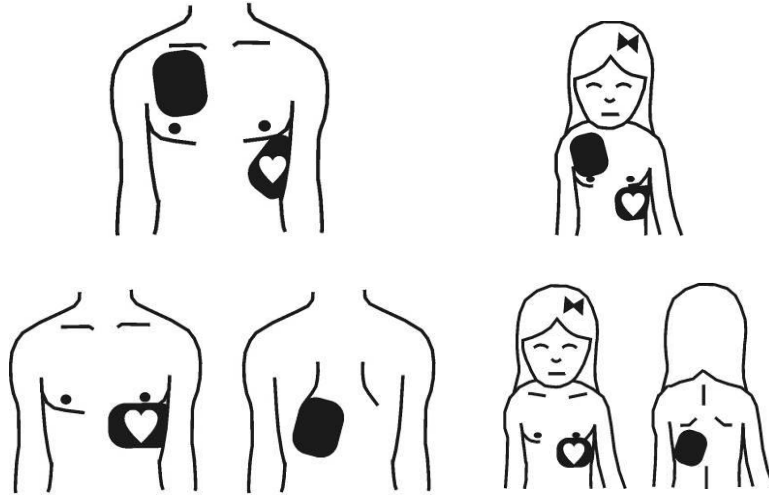

5.2.4 Adult and Paediatric mode

SMARTY Saver makes it possible to use universal defibrillation pads, i.e., that can be used on adult (age >8 or weight >25 kg) and paediatric (age from 1 to 8 or weight <25 kg) patients.

The type of patient must be selected before placing the pads on the chest, with the dedicated button on the device's keyboard (see figure below).

By pushing the dedicated button for 2 seconds, you will activate the selected mode, and the corresponding control LED will light up.

Push for 2 seconds to select "Paediatric Patient". Green LED lit.

Push for 2 seconds to select "Adult Patient". Green LED lit.

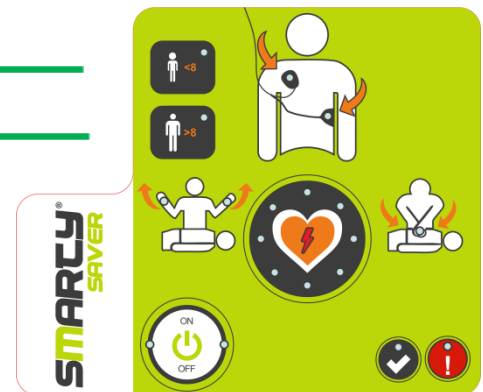

Note: When the device is switched on - by default - is supplied with the universal plates in Adult Patient mode.

5.3 μ SD memory Card

Memory cards supported are μ SD/SDHC cards with a capacity of up to 32 GB.



To install the memory card in *SMARTY Saver* please follow the procedure below:

- A. Make sure the device is switched off and place it on a hard and stable surface and remove the battery (see par. 5.1.1)
- B. Identify the housing of the μ SD card as indicated (see figure below).
- C. Lift the lid, insert the memory card with the contacts turned inwards and close the lid as indicated in figure
- D. Re-attach the battery (see par. 5.1.1)

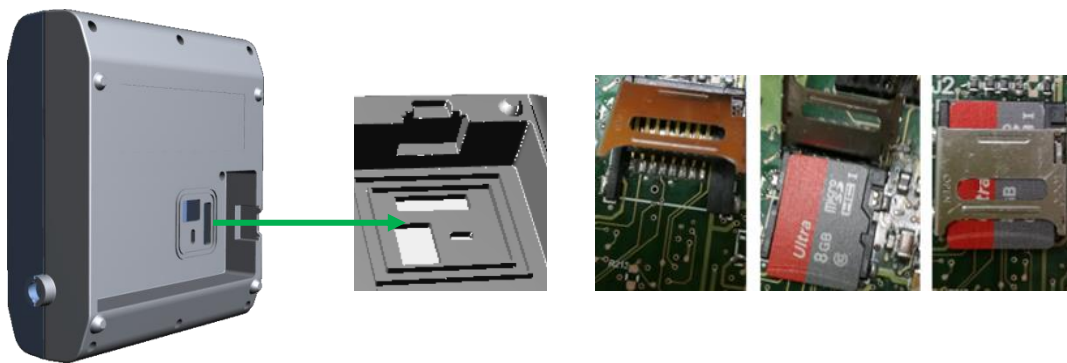

The data recorded directly on the μ SD memory can be downloaded and displayed on a PC using the SaverViewExpress software owned by A.M.I. Italia S.r.l.

5.4 SaverViewExpress



SaverViewExpress (SVE) is the PC-based software owned by A.M.I. Italia S.r.l. for managing the multimedia files (*.AED) that A.M.I. Italia S.r.l. defibrillators are able to record, for the *SMARTY Saver* series, on external memory card.

Data recording on the μ SD card occurs only if it has been inserted into the defibrillator before turning on the device, if it is left inserted for the entire duration of the rescue and removed only after turning off the defibrillator.

The data contained in the file recorded by the defibrillator are:

- The ECG trace analyzed by the device during the rescue (n.b. there is no intrinsic reference to the patient's personal data but only to the device used and the date of the rescue)
- characteristic events of the rescue (bpm, event duration, keys pressed, patient impedance, shock request, number of shocks, delivered shock energy)
- ambient audio (if microphone has been enabled)

The SVE plays an *.AED file allowing the data contained in it to be displayed.

The SVE allows to:

- make measurements on the ECG trace or on parts of it with the help of cursors
- play back the audio recorded during the rescue
- print the trace
- change the horizontal (time: mm/sec) and vertical (amplitude: mm/mV) representation scales
- manually fill a personal patient sheet to associate to the recorded file as data storage aid.

With SVE, the *.AED file it can be accessed and played in one of the following ways:

- after switching off the device, by extracting the memory card and inserting it into the PC
- after switching off the device and not removing the μ SD card from it, by connecting the defibrillator directly to the PC (on which the appropriate drivers released by A.M.I. Italia S.r.l. must be installed) via the USB port on

the back. Opening the SVE, the program provides a special "CONNECT" button that allows direct access to the contents of the memory card (still present in the device) and to show all the *.AED files stored on it.

The USB port on A.M.I. Italia S.r.l. defibrillators of the *SMARTY Saver* series is Type C

The USB port is for A.M.I. Italia S.r.l. service use only, therefore A.M.I. Italia S.r.l. disclaims all liability for inappropriate or non-compliant use as described herein.

6 Self-test

SMARTY Saver was designed to be a totally safe device, always ready to use and able to automatically and constantly check the proper operation of its parts, reducing maintenance operations by the user to a minimum.

In fact, *SMARTY Saver* performs three types of self-test:

- **Activation:** On insertion of the battery
- **Automatic:** In stand-by mode, daily/monthly/bi-annually
- **Power On:** On the device being switched on

The result of the test is showed through the control LEDs (green and/or red) that make it possible to see, at any time, when the device is switched off (stand-by mode), the operating status of the device and its main accessories.

SMARTY Saver performs the operation tests only when the battery is installed; we, therefore, recommend not to remove the battery from the device, except only for the time needed to replace it.

6.1 ACTIVATION test

On each insertion of the battery, the device will perform the ACTIVATION diagnostic test; this self-test results in a small consumption of energy, as it involves all components of the device and also requires a manual intervention by the operator, who must:

❖ Insert the battery in the device

If the battery has been inserted properly, *SMARTY Saver* will automatically switch on, the “on” button  will turn green while the control LED will switch off.

The device will emit voice messages suggesting the operation to be followed.

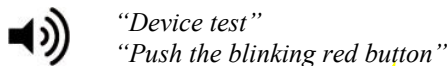

The shock button will start blinking.



The operator will have a maximum of 60 seconds* to push the shock button.

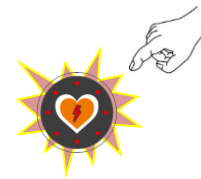

❖ Push the shock button to launch the ACTIVATION test*

If the shock button is pressed correctly, it will stop flashing and the device will launch the activation test.

**If the shock button is not pushed within 60 seconds, SMARTY Saver detects an error and switches off; disconnect and reconnect the battery to repeat the activation test and push the shock button within the time limit, to complete the test.*

If, instead, the shock button was pushed but continues to blink, the shock button is not working properly.

In such case, contact the authorised technical support centre.

If the test ends with an error, the device switches off automatically and the red control LED will blink approximately every 6 seconds. If, instead, the device activation test concludes without errors, the device will emit the voice message "place the Pads"; the two red LEDs of the "place the PADS" indicator on the keypad will blink.

❖ Switch off the device

If immediate use is not required, switch off *SMARTY Saver* and leave the battery inserted to guarantee the performance of periodic diagnostic self-tests (see following Paragraph)

6.2 AUTOMATIC test

In stand-by mode (device off and battery installed), the AED performs automatic diagnostic tests:

- Daily (basic tests with minimum battery consumption)
- Monthly (in-depth test with moderate battery consumption)
- Bi-annually (full test with substantial battery consumption)

The automatic self-tests do not require any manual operation by the operator; the outcome can be checked with the control LEDs on the device's keyboard (Please see paragraph 4.2 & 6.4).

6.3 POWER ON test

SMARTY Saver performs a diagnostic self-test every time it is switched on.









This test is performed in order to check the proper operation of the device before use, is automatic and takes a few seconds.

When the power button is pushed, the LEDs on either side of the button will turn on, and the control LED will switch off. If no errors are found following the test, the device will be ready to be used and will provide the operator with the first instructions to initiate the intervention.

6.4 Control LEDs

The control LEDs are placed on the keyboard of the *SMARTY Saver*.

Based on the various colours of the control LED, the operator can independently deduce the operation status of the defibrillator and of its main accessories. The table below shows the control LED blinking codes:

Device mode	Blinking LED	
STAND-BY (turned off with battery connected)		Device ready for use
	 +	Warning for a low battery level, replace the battery
		
		Faulty device, service required
	 +  +	Face to Face PADs expired or degraded
IN USE	OFF	Device working
	OFF + 	Warning: battery is getting low (5% left), replace it ASAP
	 + 	Caution! low battery replace it immediately

7 Defibrillation

7.1 “Chain of survival”

If it is necessary to aid a person suffering from Sudden Cardiac Arrest, please remember to follow the sequence of actions recommended by the international guidelines AHA/ERC.

The guidelines have endorsed an aid protocol to be complied with during the resuscitation of a person suffering from Sudden Cardiac Arrest; this protocol has been given the name “chain of survival”.

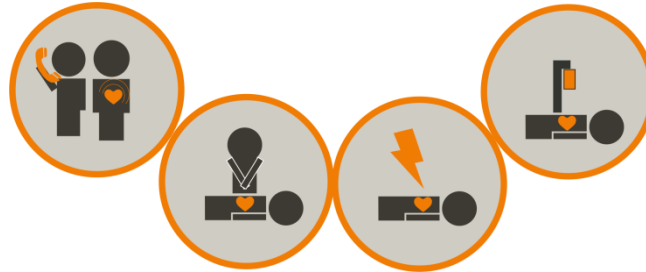

- 1 Make sure that the person is unconscious, is not breathing and has no heartbeat and call the emergency number immediately.
- 2 While waiting for a defibrillator to become available, start Cardio-Pulmonary Resuscitation manoeuvres immediately.
- 3 Switch on the defibrillator and follow the audio instructions to restore normal heartbeat.
- 4 Continue until the arrival of medical personnel.

7.2 Switching SMARTY Saver on

Push the device’s ON/OFF button



As confirmation, the LEDs of the ON/OFF button will light up steady green.

If the power on self-test has a positive result, the device will suggest to the operator the first operations to be performed by emitting voice (audio) and visual (illuminated icons) commands:

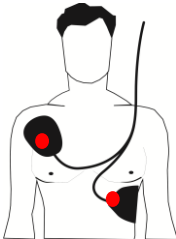
Voice messages	Keyboard Illuminated Icons
Make the emergency call	 <p data-bbox="1099 1711 1299 1798">Command Place the defibrillation pads</p>
<p>Keep calm and follow the voice instructions. If the patient is unconscious and is not breathing, remove their clothes in order to apply the electrodes to the patient’s naked chest</p>	
<p>Open the packaging and look carefully at the images on the electrodes Remove the plastic wrapping from the electrode and place it squarely on the patient’s chest, as shown in the images</p>	

7.3 Preparing the patient

In order to be able to place the defibrillation pads on the chest, you must perform the preliminary operations below:

- Remove clothing from the patient's chest
- If the patient's chest is very hairy, you must shave the places where the pads will be placed.

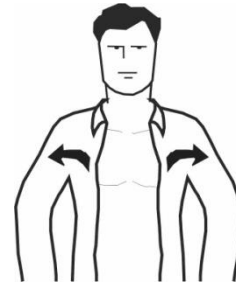

7.4 Place the pads

A Take the defibrillation pads out of their original packaging.

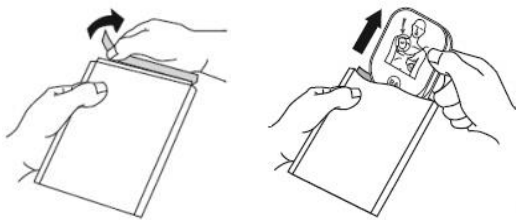

B Remove the individual pad's protective film and place it on the patient's chest

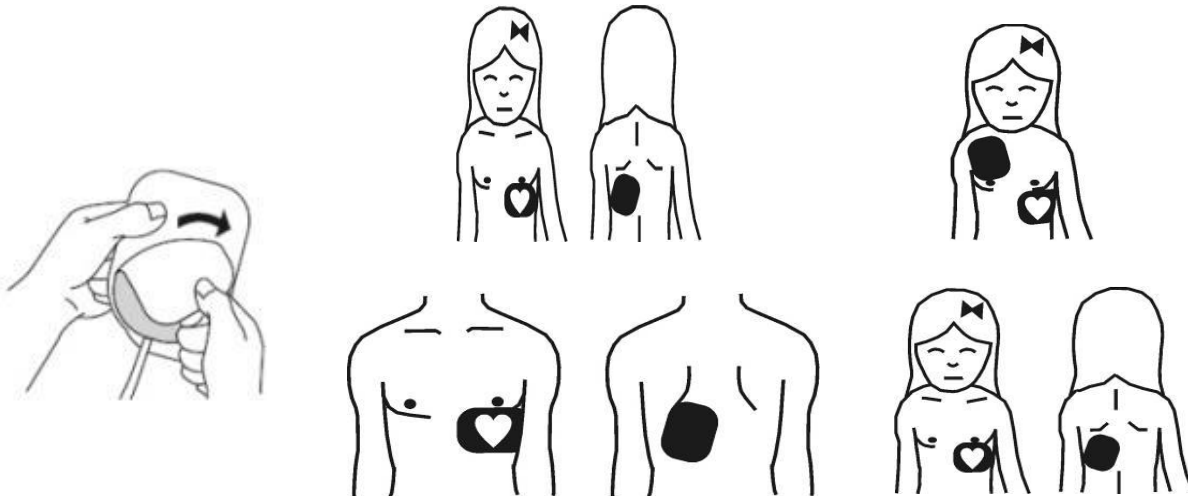

The correct placement of the pads is essential for an effective analysis of the patient's heartbeat and for the consequent delivery of the shock, if needed.

If the patient is a child (age from 1 to 8 or weight <25 kg), before placing the defibrillation pads on the patient's chest, select the paediatric mode with the dedicated selector on the AED's keyboard (please see paragraph 5.2.4 for more information).

Note: Please always refer to the instructions on the packaging and to the specific user manual of the pads.

7.5 Heartbeat analysis



If the defibrillation pads have been applied correctly on the patient and the connector has been inserted in the dedicated compartment, **SMARTY Saver** will automatically analyse the patient's heartbeat.

During the heartbeat analysis, the patient's body must not be touched and it must not be subject to vibrations or movements.

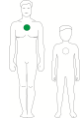
This stage of the analysis is characterised by the following voice messages:

Voice commands	Keyboard Illuminated Icons
Do not touch the patient	 <p>Icon "do not touch the patient" lit without blinking</p>
Heartbeat analysis in progress	 <p>Icon "pad type used" Adult or child lit without blinking</p>

The analysis software of **SMARTY Saver** has been designed to recommend the treatment with defibrillation shock only if the patient is suffering from the following arrhythmias:

VF Ventricular Fibrillation	 <p>Peak-to-peak amplitude of min. 200 μVolts Certain rhythms with a very low amplitude or low-frequency VF can be interpreted as non-defibrillable.</p>
VT Ventricular Tachycardia (including ventricular flutter and polymorphic ventricular tachycardia)	 <p>Rhythm frequency min. 180 bpm and peak-to-peak amplitude of min. 200 μVolts. Certain rhythms with a very low amplitude or low-frequency VT can be interpreted as non-defibrillable.</p>





The presence of noise artefacts (caused, for example, from the patient's movement or from the regulation of the defibrillation electrodes) or electronic disturbance emitted by external sources may delay or interrupt the ECG analysis.

Note: The **SMARTY Saver** analysis software can filter pulses originating from an implanted pacemaker.

7.6 Defibrillable rhythm

If a Ventricular Fibrillation or Tachycardia is detected, *SMARTY Saver* will inform the operator with the following commands:

Voice messages	Illuminated Icons/Buttons
Shock recommended	 <p>Icon “do not touch the patient” Lit without blinking</p>
Keep your distance, charging	 <p>Shock icon blinking</p>
Push the blinking red button	

To deliver the shock, push the shock button within 15 seconds from the voice message, making sure that no one is touching the patient.

If the shock button is not pushed within 15 seconds from the shock warning, *SMARTY Saver* will disarm automatically. At this stage, the shock button will no longer blink and the device will inform the operator with the following voice messages:

Voice messages
Shock Cancelled
The shock button was not pushed

If, instead, the shock button is pushed within the 15 seconds, *SMARTY Saver* will make the defibrillation shock. At this stage, the shock button will no longer blink and the device will inform the operator with the following voice messages:

Voice messages
Shock delivered

SMARTY Saver delivers the shock using the BTE waveform with automatic compensation of the patient’s thoracic impedance. The value of the impedance detected must range between 20 and 200 Ohm; if the value detected is outside of this range, the device will ask for the pads to be placed once more.

The shock protocol of *SMARTY Saver* is incremental, i.e., the energy delivered to the patient varies incrementally based on the number of shocks performed:

- first shock, energy 150J
- subsequent shocks at 200J.

The shock protocol is pre-set, cannot be modified by the user and it’s reset after power off of the device. The protocol can be modified and customized only and exclusively by A.M.I. Italia S.r.l. following an explicit request from the customer (endorsed by a responsible body).

7.7 Change of rhythm

SMARTY Saver performs a continuous analysis of the patient's heartbeat, throughout resuscitation.

If, after having recommended the shock, the device detects a change in the patient's heartbeat which no longer requires defibrillation, the AED will disarm automatically.

In this case, you will hear the following commands:

Voice messages
Shock cancelled
Rhythm changed

7.8 Non-defibrillable rhythm

If, during the analysis of the heartbeat, **SMARTY Saver** does not detect a VF or a VT, it will inform the operator with the following commands:

Voice messages
Shock not recommended

All rhythms other than VT and VF will be assessed as non-defibrillable.
For more information, please see relative paragraph.

7.9 Cardio-Pulmonary Resuscitation

A **SMARTY Saver** defibrillator will guide the operator towards CPR in one of the following cases:

- A defibrillable rhythm has been detected and a defibrillation shock has been delivered
- A non-defibrillable rhythm has been detected
- A defibrillable rhythm has been detected but the shock button has not been pushed
- A defibrillable rhythm has been detected by the patient's rhythm has changed



SMARTY Saver will provide voice instructions to perform CPR, guiding the operator on how to perform the chest compressions and insufflations.



SMARTY Saver will mark the rhythm of chest compressions with a metronome; once the compressions are finished, it will ask for the insufflations to be performed.

In accordance with the requirements of the international guidelines AHA/ERC, the duration of the cardio-pulmonary resuscitation is approximately 2 minutes, with a compression/insufflation ratio of 30/2 for a total of 5 full cycles.

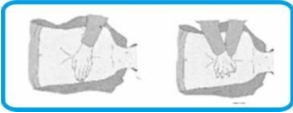
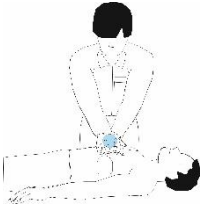
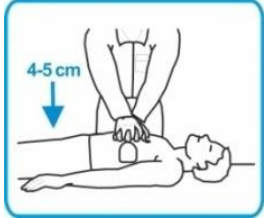
The voice instructions of **SMARTY Saver** are repeated for all cycles, i.e., for approximately 2 minutes.

The table below shows the main operations to be performed during CPR and the related visual/voice/text commands provided by *SMARTY Saver*.

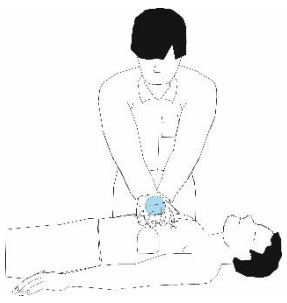
No.	Type of command	SMARTY Saver instructions	Operations to be performed
1	Voice	“Start Cardio-Pulmonary Resuscitation”	<p>A. Check that the patient is on a firm surface B. Kneel at the patient’s side C. Place the heel of one hand on the centre of the patient’s chest D. Place the heel of the other hand on top of the first E. Link the fingers of the two hands and make sure that the pressure is not applied to the ribs. Do not apply any pressure on the upper part of the abdomen or on the lower part of the sternum.</p> 
	Visual ILLUMINATED ICON		
2	Voice	“Quickly press on the patient’s chest”	<p>F. Place yourself vertically to the patient’s chest and, with arms extended, press the sternum. Keeping the arms extended, perform external cardiac massage by using the weight of the torso; the oscillating movement must be centred around the hip joint. G. After each compression, release all pressure on the chest without losing contact between your hands and the sternum; repeat the manoeuvre with a frequency of 100-120 / min (approximately 2 compressions per second) H. The compression/release phases must be of equal duration.</p> 
	Visual ILLUMINATED ICON		
	Acoustic Signal (BEEP)	a BEEP marks each compression to be performed.	
3	Voice	<p>“Perform two insufflations” “Blow” “Blow”</p>	<p>Open immediately the air passage by tilting the head and the chin backwards</p> 

	Visual ILLUMINATED ICON		<p>Perform two insufflations</p> <p>The rescuer breathes normally and, keeping the chin up with two fingers, puts their lips around the patient's mouth. The opposite hand closes the nostrils to keep the air from coming out and keeps the head hyper-extended. Air is blown in breathing normally for about 1 second</p> 
4	steps 1 to 3 will be repeated for approximately 2 minutes		Follow the voice and text instructions of <i>SMARTY Saver</i> until the device completes the CPR phase (approximately 2 minutes).

8 Recording, displaying and storing the data

The *SMARTY Saver* defibrillator records and stores, on the external memory (if present), the files generated each time the device is switched on and after each self-test (AED1LOG) and the data of the rescues performed (*.AED FILE).

8.1 Files that can be stored.

The data that can be stored on the μ SD Card external memory can be divided into two types of files:

- **AED1LOG.txt:** files generated each time the device is manually switched on and after each automatic self-test performed by the device, with its outcome. The files can be displayed on a PC using a simple software that reads them.
- ***.AED:** data of the rescue, such as environmental recordings (audio), ECG trace, patient data (patient Heart Rhythm and thoracic impedance) and all events of the rescue. The files can be displayed on a PC with the SaverViewExpress software owned by A.M.I. Italia S.r.l..

The number and duration of the recordings depend on the storage capacity of the μ SD Card; an 8 GB μ SD card makes it possible to store approximately 400 hours of recordings/data.

8.2 Storage of data on a PC

The data recorded by the *SMARTY Saver* defibrillator and saved on the μ SD external memory can be stored in, analysed by and printed from a PC with the management software SaverViewExpress (SAV-C0019).

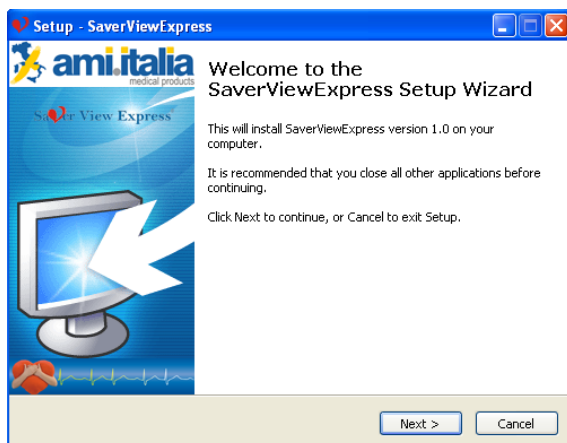

Note: For more details on the PC SaverViewExpress software, please consult the related user manual.

9 Possible Residual Risks and Remedies:

RESIDUAL RISK WITH THE END USER	ASSOCIATED HAZARD ID'S	CONCLUSION
<p>Skin infection & Second degree skin burn, inconvenience to the user, delayed treatment</p>	<p>C.11, C.20, E.3, F.4, H.1, H.2, H.4, H.6, H.7, H.8, H.9, H.11, H.12, J.1, J.2</p>	<p>The device is configured for Public use and intended to be maintained by the installer. As a standard practice the installer/owner of the device contacts the dealer/distributor for any service/battery replacement queries. Instructions for use clearly mentioned with service shall be done by authorized representative. Hence the chance of attempting un-authorized service is very remote. By considering the medical benefits of the device, user shall avoid this hazard by following the overlay information, voice commands & Instruction for use. Hence the benefits of this device outweigh this residual risk.</p> <p>Defibrillator starts with Semi-Automatic mode by default. Device delivers clear voice prompts in local language and guides the user. Device proceeds further only when the previous step completed successfully. In addition to the voice prompt, the device pasted with pictorial information, and LED indications. The user shall follow these instructions in case of any emergency. By considering the medical benefits of the device, user shall avoid this hazard by following the overlay information, voice commands & Instruction for use. Hence the benefits of this device outweigh this residual risk.</p> <p>The device is stored in a bag and kept inside an enclosure. Hence the chance of getting dusted is very rare. After usage, the device needs only surface cleaning by using a soft cloth. No other requirements. electrodes are one time used and cannot be used for other patient in a normal use. Hence the benefits of this device outweigh this residual risk.</p> <p>Information towards ambient condition, cleaning & Disinfection are clearly mentioned in Instruction for use. By considering the medical benefits of the device, user shall avoid this hazard by following the Instruction for use. Hence the benefit of this device outweighs this residual risk.</p> <p>Device basic safety information is given in Instruction for use. Also Instruction for use clearly says that the user shall inform manufacturer if the label peels from the device. Hence the benefit of the device outweighs this residual risk.</p> <p>The device is intended to be operated by common person/healthcare professionals. Training provided while installing the device.. Hence the benefit of the device outweighs this residual risk.</p> <p>Device first time installation by the company person/Authorised representative. Device marked with required warning symbols. Hence the benefit of the device outweighs this residual risk.</p>

		<p>We have established and maintaining the strong quality management system and regular process monitoring controls as per EN ISO 13485: 2016/A11:2021 requirements. As part risk management process, all possible risk control measures are implemented to reduce the risk to acceptable levels in a reasonably practicable way. The information of safety to the target user is communicated in the form of Instructions for Use. Hence the occurrence of defined hazardous situations is very rare.</p> <p>We have identified and analysed the medical & clinical benefits when related, external cardiac defibrillator is used as per the instruction provided in IFU. The clinical benefits are out weighting against to the residual risk. While considering the device clinical benefits, the occurrence of this risk is very minimal in daily use.</p> <p>This hazard occurrence will be due to end user negligence to follow the IFU, label symbols which using the external cardiac defibrillator. The directions for safe and effective opening of the external cardiac defibrillator package is communicated to the end user through the IFU, package label supplied along with each pack. This residual risk cannot be controlled by the manufacturer, and this risk occurrence is only be eliminated when the end user strictly adheres to the information of IFU and label. However, the target users for external cardiac defibrillator are common public/healthcare professionals and they are well aware of use instructions. Hence the occurrence of defined hazardous situations is very rare.</p> <p>We have identified and analysed the medical & clinical benefits related when external cardiac defibrillator is used as per the instruction provided in IFU. The clinical benefits are out weighting against to the residual risk. While considering the device clinical benefits, the occurrence of this risk is very minimal in daily use.</p> <p>The external cardiac defibrillator storage limits are communicated to the end user through the IFU & Label symbol with each package. If the external cardiac defibrillator are not stored in specified conditions, which may lead deterioration in performance. This residual risk cannot be controlled by the manufacturer, and this risk occurrence is only be eliminated when the end user strictly adheres to the information of IFU and label. However, the target users for external cardiac defibrillator are common public/healthcare professionals and they are well aware of the use instructions. Hence the occurrence of defined hazardous situations is very rare.</p> <p>We have identified and analysed the medical & clinical benefits related when external cardiac defibrillator is used as per the instruction provided in IFU. The clinical benefits are out weighting against to the residual risk. While considering the device clinical benefits, the occurrence of this risk is very minimal in daily use.</p> <p>The external cardiac defibrillator use by date is printed on the label. The user has to check the use by date mentioned on the label. If the user fails to check the expiry date and used the expired product may infect the patient. This residual risk cannot be controlled by the manufacturer, and this risk occurrence is only be eliminated when the end user strictly adheres to the information of IFU and label. However, the target users for external cardiac defibrillator</p>
--	--	---

		<p>are common public/healthcare professionals and they are well aware of the use instructions. Hence the occurrence of defined hazardous situations is very rare.</p> <p>The external cardiac defibrillator is supplied in neatly packed condition and the information is printed on the product label. The clear instructions are available in IFU as well. If the external cardiac defibrillator package is damaged or wet the user need to discard that product, if he/she fails the usage may result in Infection. This residual risk cannot be controlled by the manufacturer, and this risk occurrence is only be eliminated when the end user strictly adheres to the information of IFU and label. However, the target users for external cardiac defibrillator are common public/healthcare professionals and they are well aware of the use instructions. Hence the occurrence of defined hazardous situations is very rare.</p> <p>We have identified and analysed the medical & clinical benefits related when external cardiac defibrillator is used as per the instruction provided in IFU. The clinical benefits are out weighting against to the residual risk. While considering the device clinical benefits, the occurrence of this risk is very minimal in daily use</p> <p>Device supplied with custom made electrode connector and housing for better holding and to maintain least contact resistance. The Electrode length is sufficiently designed so that the device can be kept at safe and stable. Hence the benefits of the device outweigh this residual risk.</p>
<p>Unresponsive patient, Allergic reaction, first degree skin burn, inconvenience to the user</p>	<p>A.2, A.10, C.29, F.5, F.6, G.1, G.2, G.3, G.4, G.5, G.6, G.7, G.9, G.10, G.11, G.12, G.13, G.14, G.15, G.17, G.18, G.19, G.20, G.21, G.22, G.23, G.24, G.25, H.10</p>	<p>The device designed with Battery supervisory circuit and while performing the verification, Battery endurance test performed and ensured. The device delivers low battery warning and also on every session report via cloud and in logfile. The owner of the device receives battery information frequently. So the chance of unattended device situation is very remote. Hence the benefits of this device outweigh this residual risk</p> <p>The device requires only the electrode to be connected for its use. the electrode connector and housing made for unipolar type so that The user can insert in one direction to avoid any reverse connection. Also, the connection diagram is clearly indicated on the device. By considering the medical benefits of the device, user shall avoid this hazard by following the overlay information, voice commands & Instruction for use. Hence the benefits of this device outweigh this residual risk.</p> <p>Though the device's PADs designed with long duration, it's the responsibility of the owner/service provider to ensure replacing the electrodes before expiry. By considering the medical benefits of the device, user shall avoid this hazard by following the overlay information, voice commands & Instruction for use. Hence the benefits of this device outweigh this residual risk.</p> <p>The device needs minimal maintenance like surface cleaning and the accessories are one time use. All the indications and Troubleshooting information for any misuse are given in the Instruction for use. By considering the medical benefits of the device, user shall avoid this hazard by following the Instruction for use. Hence the benefit of</p>

		<p>this device outweighs this residual risk.</p> <p>Instruction for use mentioned with clear instructions with pictorial reference for every option/mode to be used. Also, the device overlay is printed with pictorial information of usage of the device and the device delivers clear voice prompt in local language. Hence the benefit of this device outweighs this residual risk.</p> <p>This hazard occurrence will be due to end user negligence to follow the IFU, label symbols which using the external cardiac defibrillator. The directions for safe and effective opening of the external cardiac defibrillator package is communicated to the end user through the IFU, package label supplied along with each pack. This residual risk cannot be controlled by the manufacturer, and this risk occurrence is only be eliminated when the end user strictly adheres to the information of IFU and label. However, the target users for external cardiac defibrillator are common public/healthcare professionals and they are well aware of use instructions. Hence the occurrence of defined hazardous situations is very rare.</p> <p>We have identified and analysed the medical & clinical benefits related when, the external cardiac defibrillator is used as per the instruction provided in IFU. The clinical benefits are out weighting against to the residual risk. While considering the device clinical benefits, the occurrence of this risk is very minimal in daily use.</p> <p>The directions of safe and effective handling of the external cardiac defibrillator are communicated to the end user through the IFU supplied along with each pack. The unskilled user can put the user and patient at the risk of contamination and cross infection due to the mishandling of the device. This residual risk cannot be controlled by the manufacturer, and this risk occurrence is only be eliminated when the end user strictly adheres to the information of IFU and label. However, the target users for external cardiac defibrillator are common public/healthcare professionals and they are well aware of the use instructions. Hence the occurrence of defined hazardous situations is very rare.</p> <p>We have identified and analysed the medical & clinical benefits related when external cardiac defibrillator is used as per the instruction provided in IFU. The clinical benefits are out weighting against to the residual risk. While considering the device clinical benefits, the occurrence of this risk is very minimal in daily use.</p> <p>These hazard during shock release alerts were prepared to inform the user that the device produces high voltage and current during operation and it captures information on high voltage on the label of the device. In addition, Instruction for use is provided with warnings and the presence of the risk of electrocution is made clear to the user.</p> <p>We have identified and analysed the medical & clinical benefits related when, the external cardiac defibrillator is used as per the instruction provided in IFU. The clinical benefits are out weighting against to the residual risk. While considering the device clinical benefits, the occurrence of this risk is very minimal in daily use.</p> <p>This hazard occurrence will be due to end user negligence to follow the IFU, label symbols which using the external</p>
--	--	---

		<p>cardiac defibrillator. The directions for safe and effective opening of the external cardiac defibrillator package is communicated to the end user through the IFU, package label supplied along with each pack. This residual risk cannot be controlled by the manufacturer, and this risk occurrence is only be eliminated when the end user strictly adheres to the information of IFU and label. However, the target users for external cardiac defibrillator are common public/healthcare professionals and they are well aware of use instructions. Hence the occurrence of defined hazardous situations is very rare.</p> <p>We have identified and analysed the medical & clinical benefits related when external cardiac defibrillator is used as per the instruction provided in IFU. The clinical benefits are out weighting against to the residual risk. While considering the device clinical benefits, the occurrence of this risk is very minimal in daily use.</p> <p>This hazard occurrence will be due to end user negligence to follow the IFU, label symbols which using the external cardiac defibrillator. The directions for safe and effective opening of the external cardiac defibrillator package is communicated to the end user through the IFU, package label supplied along with each pack. This residual risk cannot be controlled by the manufacturer, and this risk occurrence is only be eliminated when the end user strictly adheres to the information of IFU and label. However, the target users for external cardiac defibrillator are common public/healthcare professionals and they are well aware of use instructions. Hence the occurrence of defined hazardous situations is very rare.</p> <p>We have identified and analysed the medical & clinical benefits related when external cardiac defibrillator is used as per the instruction provided in IFU. The clinical benefits are out weighting against to the residual risk. While considering the device clinical benefits, the occurrence of this risk is very minimal in daily use.</p> <p>This hazard can be avoided by giving the proper information regarding the arrangements of cables and wiring connection in the instruction for use. And warning regarding the wiring connection also mentioned in the warning section of instruction for use, hence the risk outweighs the residual risk.</p> <p>We have identified and analysed the medical & clinical benefits related when external cardiac defibrillator is used as per the instruction provided in IFU. The clinical benefits are out weighting against to the residual risk. While considering the device clinical benefits, the occurrence of this risk is very minimal in daily use.</p> <p>This hazard occurrence due to the disposal of batteries so, IFU captures the clear information regarding the disposal of batteries in disposal section user can refer that, and also warnings for the user of possible side effects is give in the Instruction for use.</p> <p>We have identified and analysed the medical & clinical benefits related when external cardiac defibrillator is used as per the instruction provided in IFU. The clinical benefits are out weighting against to the residual risk. While considering the device clinical benefits, the occurrence of this risk is very minimal in daily use.</p>
--	--	--

		<p>This hazard occurrence due to the disposal of device so, IFU captures the clear information regarding the disposal of device in disposal section user can refer that, and also warnings for the user of possible side effects is give in the Instruction for use.</p> <p>We have identified and analysed the medical & clinical benefits related when external cardiac defibrillator is used as per the instruction provided in IFU. The clinical benefits are out weighting against to the residual risk. While considering the device clinical benefits, the occurrence of this risk is very minimal in daily use.</p> <p>Device basic safety information and warning is given in Instruction for use. Also Instruction for use clearly says that the user shall inform correct methods of discharge. Hence the benefit of the device outweighs this residual risk.</p> <p>Device basic safety information and Handling of electrode is given in Instruction for use. Also Instruction for use clearly says that the how to use electrode. Hence the benefit of the device outweighs this residual risk.</p> <p>Device basic maintenance information and also warning of the device are given in the instruction for use. Also Instruction for use clearly says about the maintenance process in the maintenance section and in warning section. Hence the benefits of the device outweighs this residual risk</p> <p>Device basic maintenance information and also warning of the device are given in the instruction for use. Also Instruction for use clearly says about battery replacement maintenance section and in warning section. Hence the benefits of the device outweighs this residual risk</p> <p>Device delivers clear voice messages continuously in the process of defibrillation. Once the device senses improper body impedance, the device software delivers voice message and visual indication to the user to stay away. Hence the benefits of the device outweighs this residual risk</p> <p>The electrodes are neatly placed on runner sheet with neat clearance to the user. Also, conductive area is designed in the inner area of pads. So the chance of getting contact with the conductive area is very remote. Hence the benefits of the device outweighs this residual risk</p> <p>Pad's use by date clearly mentioned on electrode pouch. The manufacturer and the service provider/owner maintains clear log about installed devices. The chance of leaving expiry electrodes is very remote. Hence the benefits of the device outweighs this residual risk</p> <p>Adult electrodes are with larger surface area than paediatric electrodes. Also, when the device sensing incorrect body impedance the device software will start delivering voice messages to the user to check the electrodes or placement of the electrodes. Hence the benefits of the device outweighs this residual risk</p> <p>Device designed with battery supervisory circuit and will monitor and deliver about the battery status. The manufacturer and the service provider/owner maintains</p>
--	--	--

		<p>clear log about installed devices. Device also intimates the manufacturer/owner whenever reaches low battery condition. So the chance of leaving the device with low battery condition is very remote. Hence the benefits of the device outweighs this residual risk</p> <p>The device discharges the charged energy within 15 seconds from the time charged. Whenever the device force shutdown due to battery drain, device discharges the residual energy internally and will get ready for the next operation. At the time of restarting with a new battery, the device performs a self test. Also, the patient is actively isolated from the device in monitoring and self test condition. Hence the benefits of the device outweighs this residual risk</p> <p>The external cardiac defibrillator contact duration is communicated to the end user through the information on IFU & label with each pack. If the patient impedance is disconnected, the software warning the user about Patient impedance loss advised with message "connect the patient". This residual risk cannot be controlled by the manufacturer, and this risk occurrence is only be eliminated when the end user strictly adheres to the information of IFU and label. However, the target users for external cardiac defibrillator are common public/healthcare professionals and they are well aware of the use instructions. Hence the occurrence of defined hazardous situations is very rare.</p> <p>We have identified and analysed the medical & clinical benefits related when, external cardiac defibrillator is used as per the instruction provided in IFU. The clinical benefits are out weighting against to the residual risk. While considering the device clinical benefits, the occurrence of this risk is very minimal in daily use.</p>
--	--	---

9.1 Final Residual Risk Status

#	RESIDUAL RISK	TOTAL HAZARDS	LEADING HAZARDOUS SITUATION	HAZ ID DETAILS	STATUS
1.	Skin infection & Second-degree skin burn, inconvenience to the user, delayed treatment	15	<ul style="list-style-type: none"> Unauthorized access Inadequate knowledge on product usage Used in contaminated environment Lack of awareness towards the maintenance of the device Label damage because of cleaning liquid. Aging of label because of chemical reaction, User unaware of essential operation Operator not trained. Information not placed at appropriate location Device not operated by the persons who did not read Instructions for use Lack of information towards the symbols and unskilled operation cautions Lack of information towards the symbols Lack of information towards unpacking information Unavailability of Storage Temperature Symbol with limits Lack of information about device expiry Lack of information about package form and fitness Accidental Pulling of electrode connector 	C.11, C.20, E.3, F.4, H.1, H.2, H.4, H.6, H.7, H.8, H.9, H.11, H.12, J.1, J.2	Accepted based on the Benefit-Risk Analysis
2.	Unresponsive patient, Allergic reaction, first degree skin burn, inconvenience to the user	29	<ul style="list-style-type: none"> Un attended device Lack of Awareness of using the device Lifetime of electrodes is exceeded Lack of awareness towards Instructions for use Lack of knowledge of Using the device User/Buyer not following the unpacking instructions provided on the packing box User/Buyer not following the unpacking instructions User/Buyer not following the operating instructions User/Buyer not following the instructions User/Buyer unaware/not following the instructions Panic Condition 	A.2, A.10, C.29, F.5, F.6, G.1, G.2, G.3, G.4, G.5, G.6, G.7, G.9, G.10, G.11, G.12, G.13, G.14, G.15, G.17, G.18, G.19, G.20, G.21, G.22, G.23, G.24, G.25, H.10	Accepted based on the Benefit-Risk Analysis

10 Maintenance

The *SMARTY Saver* defibrillator was designed to make maintenance operations simple and automatic. In fact, thanks to the control tests performed by the device itself, no extraordinary maintenance is required, just scheduled maintenance which consists in visually checking the control LED, at the same time as visually checking the related accessories. If assistance is required during the device's installation or to report any malfunctions, please use the following contact details:

email: info@amiitalia.com; Ph.: +390818060574; website: www.amiitalia.com

10.1 Maintenance after use





After having used the *SMARTY Saver* defibrillator, it is necessary to perform the following operations to ready the device for subsequent uses:

- 1 Check the presence of the memory card (if present) and its residual capacity (4.1 & 5.3)
- 2 Check that the control LED is on and blinking green
- 3 Replace the pads with a new pack

10.2 Scheduled maintenance

Thanks to the tests performed by the device itself, scheduled maintenance will require a simple and quick visual inspection following the operations described in the table:

Daily Check	Monthly Check	Check before use	Check after use	Action indicated
*		*	*	Check the control LED (see par. 6.4)
*		*	*	Check the integrity of the device, of its parts and of the accessories supplied
	*	*		Check the expiry date of the defibrillation pads
			*	Check the residual capacity of the memory card (if present)

	 CONTROLLED	  PADS EXPIRATION	 DEVICE			
Date	Is flashing only in green?		Is the date still valid?		Visual inspection	Signature
	<input type="button" value="Y"/>	<input type="button" value="N"/>	<input type="button" value="Y"/>	<input type="button" value="N"/>	<input type="button" value="ok"/>	
	<input type="button" value="Y"/>	<input type="button" value="N"/>	<input type="button" value="Y"/>	<input type="button" value="N"/>	<input type="button" value="ok"/>	
	<input type="button" value="Y"/>	<input type="button" value="N"/>	<input type="button" value="Y"/>	<input type="button" value="N"/>	<input type="button" value="ok"/>	
	<input type="button" value="Y"/>	<input type="button" value="N"/>	<input type="button" value="Y"/>	<input type="button" value="N"/>	<input type="button" value="ok"/>	
	<input type="button" value="Y"/>	<input type="button" value="N"/>	<input type="button" value="Y"/>	<input type="button" value="N"/>	<input type="button" value="ok"/>	
	<input type="button" value="Y"/>	<input type="button" value="N"/>	<input type="button" value="Y"/>	<input type="button" value="N"/>	<input type="button" value="ok"/>	
	<input type="button" value="Y"/>	<input type="button" value="N"/>	<input type="button" value="Y"/>	<input type="button" value="N"/>	<input type="button" value="ok"/>	
	<input type="button" value="Y"/>	<input type="button" value="N"/>	<input type="button" value="Y"/>	<input type="button" value="N"/>	<input type="button" value="ok"/>	

10.3 Cleaning

The structure of the **SMARTY Saver** defibrillator, including the port for the connection of the defibrillation electrodes, can be sanitised with the help of a soft cloth dampened with one of the detergent solutions listed below:

- a) Isopropyl alcohol (70% solution)
- b) Soapy water
- c) Bleach (30 ml per litre of water)
- d) Detergents containing ammonia
- e) Detergents containing glutaraldehyde
- f) Hydrogen peroxide



Do not immerse **SMARTY Saver** in any liquids.
 Do not use abrasive materials or detergents, strong solvents, such as acetone or acetone-based detergents, and enzymatic detergents.
 Do not sterilise **SMARTY Saver** or its accessories

10.4 Storage











SMARTY Saver must be placed in a place that complies with the environmental and safety conditions of the table below and at the temperature and humidity indicated in paragraph 0
 The device must be stored with the battery always inserted, to allow periodic self-testing.
 So that the device is easy to find in case it is needed, place it where it will be easily accessible and turned around so that the control LEDs are visible.

	Do not use, install or store SMARTY Saver in temperature or humidity conditions outside of the ranges mentioned in this user manual.		Do not install or store SMARTY Saver in areas directly exposed to sunlight
	Do not install or store SMARTY Saver in areas subject to significant fluctuations of temperature or humidity		Do not install or store SMARTY Saver near sources of heat
	Do not use, install or store SMARTY Saver in places subject to strong vibrations		Do not use, install or store SMARTY Saver in spaces with a high concentration of anaesthetic or inflammable gases
	Do not install or store SMARTY Saver in areas with high concentrations of dust		Tampering with SMARTY Saver can only and exclusively be done by A.M.I. Italia S.r.l. or personnel authorised thereby.

10.5 Guide to identifying faults

The table below lists the device's statuses, the possible causes and the possible corrective actions that will resolve issues that have emerged.

For more details regarding the implementation of corrective actions, please refer to the specific sections of this user manual. If the fault persists, please contact technical support.

STATUS	LED	POSSIBLE CAUSE	CORRECTIVE ACTION
The device, with the battery installed, does not switch on Both control LEDs are off	OFF	The battery is completely empty or faulty	Replace the battery. If the problem persists, please call technical support
		The device is not working	Please contact technical support
In stand-by mode, the control LED is off.	OFF	The control LED is broken	Please contact technical support
		The battery is completely empty or faulty	Replace the battery. If the problem persists, please call technical support
In stand-by mode, the control LED blinks RED.		A critical error of the device was found during the daily self-test.	Please contact technical support and eventually give them the error code.
In stand-by mode, the control LED blinks alternatively GREEN/RED.	 	Battery empty Level <1% The device could switch off during use. <i>(please see paragraph 5.1)</i>	Please replace the battery immediately
In stand-by, the control LEDs blink alternatively once GREEN and twice RED.	  	The Face-to-Face pads are about to expire or are worn	Check the expiration date on the PADS package
In operation mode, the device emits the voice message "Batteries low"	 OFF	Battery low. Battery level 5%. It is possible to use the device <i>(please see paragraph 5.1)</i>	Please prepare to replace the battery
In operation mode, the device emits the voice message "Batteries empty, please replace them"	 	The battery is empty. Level <1% The device could switch off during use. <i>(please see paragraph 5.1)</i>	Please replace the battery immediately
In operation mode, after the pads have been placed on the patient's chest, the device continues to communicate: "Place the PADS"	OFF	The PADS' connector has not been inserted correctly or has been removed	Please insert the PADS' connector correctly in the dedicated compartment
		The PADS have been placed incorrectly	Please place the PADS correctly on the patient's naked chest. If needed, remove chest hair with a razor
		The PADS are faulty	Please control that the PADS are intact and their expiry date; replace them, if needed
When inserting the battery, the AED asks you to push the shock button to launch the activation test. When the button is pushed, the test is not launched. For approximately 60 seconds, the AED asks you to push the button and then switches off automatically, while the RED LED blinks.	 	The shock button is not working	Try switching off the device and repeating the test. If the problem persists, please contact technical support
The device switches on, but no voice messages are emitted	OFF	The device's speaker is not working	Please contact technical support

10.6 Service

- Do not attempt to Dismantle/Service the Equipment.
- In case of any malfunction contact the dealer/manufacturer.
- Only company representative/service personnel are authorized to perform any service.
- Please do not perform any modifications on the equipment.
- The manufacturer/dealer/Representative shall not be responsible for any un-authorized service/Repair/Modification on this equipment.

11 Technical specifications

Below please find the technical specifications of the *SMARTY Saver* defibrillator, its parts and accessories.

11.1 Physical characteristics

Category	Rated specifications
Dimensions	200 x 213 x 71 mm (handle folded) 257 x 213 x 71 mm (handle extended)
Weight	1.56 Kg (including Pads and battery)

11.2 Environmental requirements

Category	Rated specifications
Temperature	Operational and standby: 0°C to 45°C (32°F a 113°F) -20°C (-4°F) Transient operating conditions at least 20 minutes: Storage and transport: -40°C to 70°C (-40°F to 158°F)
Relative humidity	Operational and stand-by: 10% to 95% (without condensation) Storage and transport: - without humidity control: from -40°C to +5°C - up to 90% humidity: from +5°C to +35°C - with water vapour up to 50hPa: from >35°C to +70°C
Atmospheric pressure	Operating conditions: 620hPa to 1060 hPa (calculated altitude min -382 and max 3,955 mt)
Operating conditions	Normal use: Keep the AED device within the operating and stand-by range (10% to 95% without condensation), so that the device is ready for use. Instead, after storage and transport conditions, let the device stabilise for at least 2 hours at operating conditions, before normal use.
Tolerance to shocks and falls	In compliance with standards IEC/EN 60601-1
Sealing system	In compliance with standards IEN/EN 60529 class IP56; splash-proof, dust-proof (with the battery installed)
ESD (electrostatic discharge)	In compliance with the standards IEC/EN 61000-4-2
EMC emissions/immunity	Please see paragraph 12

11.3 Reference regulatory frameworks

List of Applicable Standards

S.NO	STANDARD	TITLE
QMS STANDARD		
1.	EN ISO 13485:2016/A11:2021	Medical devices – Quality management systems
Risk Management Standard		
2.	EN ISO 14971:2019/A11:2021	Medical devices – Application of risk management to medical devices
Safety & Applicability Standards		
3.	EN 60601-1:2006+A1:2013+AC:2014 +A12: 2014 +A2: 2020	Medical electrical equipments – Part 1: General requirements for basic safety and essential performance
4.	EN 60601-1-2:2015+A1:2020	Medical electrical equipments – Part 1: General requirements for basic safety and essential performance – Collateral standard: Electromagnetic compatibility – Requirements and tests
5.	EN 60601-1-8:2007+AC:2014+A11: 2017 +A2:2020	General Requirements used for alarm systems in Medical devices
6.	EN 60601-1-11:2015+ A1: 2020	Medical electrical equipments - Part 1-11: General requirements for basic safety and essential performance - Collateral standard: Requirements for medical electrical equipments and medical electrical systems used in the home healthcare environment
7.	EN 60601-1-12:2015+ A1: 2020	General Requirements used for emergency medical service environment
8.	EN 60601-2-4:2011+ A1: 2019	Particular Requirements for cardiac defibrillators
9.	EN 62304:2006/ A1:2015	Medical device software – Software life-cycle processes
10.	EN IEC 60086-4:2019	Primary batteries - Part 4: Safety of lithium batteries
11.	IEC 60529:1989/AMD2:2013/COR1 :2019	Degrees of protection provided by enclosures (IP Code)
DIRECTIVES		
DIRECTIVE 2014/53/EU - RED		
12.	ETSI EN 301 489-1 (V2.1.1): 02-2017	Electromagnetic Compatibility (EMC) standard for radio equipment and services; Part 1: Common technical requirements; Harmonized Standard covering the essential requirements. of article 3.1(b) of Directive 2014/53/EU and the essential requirements of article 6 of Directive 2014/30/EU
13.	ETSI EN 301 489-19 Draft (V2.1.0) : 03-2017	Electromagnetic Compatibility (EMC) standard for radio equipment and services; Part 19: Specific conditions for Receive Only Mobile Earth Stations (ROMES) operating in the 1,5 GHz band providing data communications and GNSS receivers operating in the RNSS band (ROGNSS) providing positioning, navigation, and timing data; Harmonized Standard covering the essential requirements of article 3.1(b) of Directive 2014/53/EU
14.	ETSI EN 301 489-7 V1.3.1b (2005-11)	Electromagnetic compatibility and Radio spectrum Matters (ERM); Electromagnetic Compatibility (EMC) standard for radio equipment and services; Part 7: Specific conditions for mobile and portable radio and ancillary equipment of digital cellular radio telecommunications systems (GSM and DCS)
15.	Draft ETSI EN 301 489-52 V1.1.0 (2016-11)	Electromagnetic Compatibility (EMC) standard for radio equipment and services; Part 52: Specific conditions for Cellular Communication Mobile and portable (UE) radio and ancillary equipment. Harmonized Standard covering the essential requirements of article 3.1(b) of Directive 2014/53/EU
16.	EN 62311:2008 - Article 3.1a - HEALTH	Assessment Of Electronic and Electrical Equipment Related To Human Exposure Restrictions For Electromagnetic Fields (0 Hz - 300 GHz) (British Standard)
17.	ETSI EN 301 489-17 V3.2.4 (2020-09) BT - Article 3.1b - EMC	Electromagnetic Compatibility (EMC) standard for radio equipment and services; Part 17: Specific conditions for Broadband Data Transmission Systems; Harmonized Standard for Electromagnetic Compatibility

Other Directives		
18.	ANSI/AAMI EC57:2012	Testing And Reporting Performance Results Of Cardiac Rhythm And ST Segment Measurement Algorithms
19.	ANSI/AAMI DF39:1993	Automatic External Defibrillators And Remote-Control Defibrillators, 1 ^{ed}
Usability Requirement Standards		
20.	EN 60601-1-6:2010+A1:2015 + A2:2020	Medical electrical equipments – Part 1: General requirements for basic safety and essential performance – Collateral standard: Usability
21.	EN 62366-1:2015+AC:2015 +AC: 2016+A1:2020	Medical devices – Application of usability engineering to medical devices
Informational (Label & IFU) Standards		
22.	EN ISO 15223-1:2021	“Medical devices. Symbols to be used with information to be supplied by the manufacturer – Part 1: General requirements”
Bio-Compatibility, Processing of Medical Devices, Cleaning & Disinfection		
23.	EN ISO 10993-1:2020	Biological evaluation of medical devices - Part 1: Evaluation and testing within a risk management process
24.	EN ISO 10993-5:2009	Biological evaluation of medical devices - Part 5: Tests for in vitro cytotoxicity
25.	EN ISO 10993-11:2018	Biological evaluation of medical devices - Part 11: Tests for systemic toxicity
26.	EN ISO 10993-12:2021	Biological evaluation of medical devices - Part 12: Sample preparation and reference materials (ISO 10993-12:2021)
27.	EN ISO 17664-1:2021	Processing of health care products - Information to be provided by the medical device manufacturer for the processing of medical devices (ISO 17664:2017)
28.	EN ISO 10993-23:2021	Biological evaluation of medical devices - Part 23: Tests for irritation
29.	ISO 20417:2021	Medical devices - Information to be supplied by the manufacturer
30.	ISO/TR 24971:2020	Medical devices — Guidance on the application of ISO 14971
31.	ISO 10993-10:2021	Biological evaluation of medical devices - Part 10: Tests for irritation and skin sensitization

List of Applicable Guidelines

#	Regulation and Guidelines	Title
1.	REGULATION (EU) 2017/745	Regulation (Eu) 2017/745 of the European Parliament And Of The Council of 5 April 2017 on medical Devices, amending Directive 2001/83/EC, Regulation (EC) No 178/2002 and Regulation (EC) No 1223/2009 and repealing Council Directives 90/385/EEC and 93/42/EEC
2.	MDR 2017/745 Annex XIV, Part A & Part B	Clinical Evaluation – A guide for Manufacturers and Notified Body
3.	MDCG 2018-1	Guidance on BASIC UDI-DI and changes to UDI-DI
4.	MDCG 2018-4	Annex: UDI database Definitions/Descriptions and formats of the UDI core elements for systems or procedure packs
5.	MDCG 2019-1	MDCG guiding principles for issuing entities rules on Basic UDI-DI
6.	MDCG 2019-4	Timelines for registration of Device data elements in EUDAMED
7.	MDCG 2019-5	Registration of legacy Devices in EUDAMED
8.	MDCG 2019-9	Summary of safety and clinical performance A guide for manufacturers and notified bodies
9.	MDCG 2020-5	Clinical Evaluation – Equivalence. A guide for manufacturers and notified bodies
10.	MDCG 2020-6	Regulation (EU) 2017/745: Clinical evidence needed for medical Devices previously CE marked under Directives 93/42/EEC or 90/385/EEC A guide for manufacturers and notified bodies
11.	MDCG 2020-7	Post-market clinical follow-up (PMCF) Plan Template. A guide for manufacturers and notified bodies
12.	MDCG 2020-8	Post-market clinical follow-up (PMCF) Evaluation Report Template: A guide for manufacturers and notified bodies
13.	MDCG 2020-10/1	Safety reporting in clinical investigations of medical Devices under the

		Regulation (EU) 2017/745
14.	MDCG 2020-13	Clinical evaluation assessment report template
15.	MDCG 2020-15	MDCG Position Paper on the use of the EUDAMED actor registration module and of the Single Registration Number (SRN) in the Member States
16.	MDCG 2021-1	Guidance on harmonised administrative practices and alternative technical solutions until EUDAMED is fully functional
17.	MDCG 2021-5	Guidance on standardisation for medical Devices
18.	MDCG 2021-19	Guidance note integration of the UDI within an organisation's quality management system
19.	MDCG 2021-24	Guidance on classification of medical Devices

11.4 Table of Alarms

Priority	Cause	Visual signal
HIGH	Device ready to administer shock	Blinking shock button
HIGH	Battery empty (capacity < 1%)	Blinking control LED

11.5 Controls and indicators

Category	Rated specifications
Buttons	<ul style="list-style-type: none"> • ON/OFF: switches the device on and off • Shock: delivery of the defibrillation shock • “Adult” selection • “Paediatric” selection
Visual Indicators	<ul style="list-style-type: none"> • Device status control LED (2 LEDs: red and green) • Defibrillation pad placement LED (2 red LEDs) • Do not touch the patient LED (2 red LEDs) • You can touch the patient LED (1 green LED) • Adult patient LED (1 green LED) • Paediatric patient LED (1 green LED) • ON/OFF button LED (2 green LEDs) • Shock button LED (8 red LEDs)
Audio Indicators	Audio messages for instructions during use Warning and hazard acoustic signals
Speaker	Preset volume (Emissions compliant with IEC/EN 60601-2-4 point 6.1) Variation min. 20% max 100% (60 dBA to 80dBA ±3 dBA)
Microphone	Automatically activated recording on device switching on

11.6 Data memory

Category	Rated specifications
External memory (optional)	µSD/SDHC-type Memory Card up to 32 GB (max)
Stored data	AED1LOG.txt Daily self-tests, Errors detected, Device use data, Device information
	*.AED Rescue data, Environmental voices and sounds, Rescue ECG trace, Analysed and detected patient vital parameters
Data display	Through PC SaverViewExpress Software (Microsoft Windows compatible)

11.7 Defibrillator

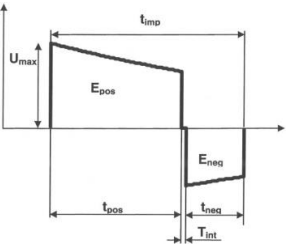
Category	Rated specifications
Waveform 	Biphasic Truncated Exponential (BTE) The waveform parameters are regulated automatically depending on the patient's autonomy. In the graph on the left, t_{pos} represents the duration of phase 1 (ms), t_{neg} represents the duration of phase 2 (ms), t_{int} is the delay between the phases, U_{max} indicates the peak voltage, t_{imp} is the end voltage. In order to compensate for variations in patient impedance, the duration of each phase of the waveform is regulated dynamically based on the shock delivered, as indicated in the following paragraph.
Max Energy delivered (Adults)	nominal 200J
Adult shock protocol	Incremental: <i>First: 150J – Subsequent: 200J</i>
Max Energy delivered (Children)	nominal 50 J
Children shock protocol	Fixed: <i>First and subsequent: 50J</i>
Charge control:	Automatic through a patient analysis system
Charge time (from shock warning)	≤ 9 sec (150J@50Ohm with new fully charged battery) ≤ 12 sec (200J@50Ohm with new fully charged battery)
Charge time (from the start of the analysis)	≤ 13 sec (150J@50Ohm with new fully charged battery) ≤ 16 sec (200J@50Ohm with new fully charged battery)
Indication of full charge	<ul style="list-style-type: none"> • The SHOCK button is blinking • Voice message "Push the blinking red button"
Delivery of the shock	The shock is delivered by pushing the "SHOCK" button
Disarming	<p><i>Automatic:</i></p> <ul style="list-style-type: none"> • If the patient analysis system considers the rhythm to be no longer defibrillable, or • If the operator has not pushed the SHOCK button within 15 seconds from completion of the charge, or • If the defibrillation pads have been removed from the patient or disconnected from the unit. <p><i>Manual:</i></p> <ul style="list-style-type: none"> • If the operator pushes the OFF/DEACTIVATION button, at any time, to deactivate or switch off the device.
Shock detection vector	Through the defibrillation pads (Lead II)
Patient insulation	Through the Type BF defibrillation pads

11.8 Efficiency of the energy delivered

Impedance	Shocks at 50 J (Paediatric)				Energy delivered (Joules)
	T _{pos} (ms)	T _{neg} (ms)	U _{max} (V)	Energy set (J)	
25 Ohm	7.2	4.3	513	50	54.8
50 Ohm	7.2	3.7	653	50	50.7
75 Ohm	8	3.7	503	50	51.8
100 Ohm	8	3.7	421	50	52.0
125 Ohm	8	3.7	368	50	52.3
150 Ohm	8	3.7	327	50	51.9
175 Ohm	8	3.7	299	50	52.5

Impedance	Shocks at 150 J				Energy delivered (Joules)
	T _{pos} (ms)	T _{neg} (ms)	U _{max} (V)	Energy set (J)	
25 Ohm	3.7	7.3	1370.0	150	150.6
50 Ohm	5.5	5.4	1536.0	150	149.9
75 Ohm	7.4	3.7	1065.0	150	151.05
100 Ohm	6.8	4.0	815.0	150	149.6
125 Ohm	7.6	3.5	663.0	150	144.75
150 Ohm	10.0	3.9	557.0	150	149.7
175 Ohm	11.3	4.5	480.0	150	147.35

Impedance	Shocks at 200 J				Energy delivered (Joules)
	T _{pos} (ms)	T _{neg} (ms)	U _{max} (V)	Energy set (J)	
25 Ohm	3.9	8.0	1370.0	200	183.6
50 Ohm	7.2	7.7	1536.0	200	196.5
75 Ohm	9.1	7.7	1065.0	200	194.7
100 Ohm	11.2	8.3	815.0	200	192.2
125 Ohm	13.0	9.7	663.0	200	191.5
150 Ohm	15.0	10.6	557.0	200	189.3
175 Ohm	15.2	9.8	480.0	200	179.55

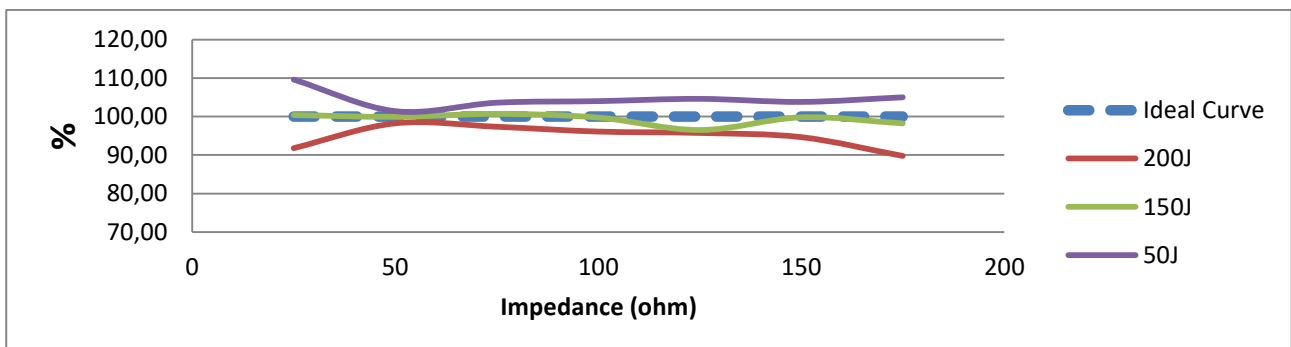

Delivered energy efficiency graph

11.9 Patient analysis system

Category	Rated specifications
Function	It determines patient impedance and assesses the ECG rhythm and the quality of the signal, to determine whether administering the shock is appropriate or not.
Impedance range	20 - 200 Ω
ECG analysis time	≥ 4 seconds (with new, fully charged battery) in compliance with the standards IEC/EN 60601-2-4
Sensitivity	97% in compliance with the standards IEC/EN 60601-2-4
Specificity	99% in compliance with the standards IEC/EN 60601-2-4
Defibrillable rhythms	If used on a patient with the characteristics listed in the use criteria, the <i>SMARTY Saver</i> defibrillator is designed to suggest a defibrillating shock when it detects the right impedance and when the following situations occur: <i>Ventricular Fibrillation</i> peak-to-peak amplitude at least 200 μ Volts <i>Ventricular tachycardia</i> with heartbeat frequency min. 180 bpm and peak-to-peak amplitude at least 200 μ Volts (including ventricular flutters and polymorphic Ventricular tachycardia)
Non-defibrillable rhythms	<i>SMARTY Saver</i> is designed not to suggest shocks with all other rhythms, including: normal sinus rhythm, moderate ventricular fibrillation (<200 μ Volts), some slow ventricular tachycardias and asystole.

11.10 ECG Analysis operation

ECG rhythm	Dimension Test sample	Objective	Value detected
Rhythm to be defibrillated Ventricular Fibrillation (VF)	500	Sensitivity > 90%	98%
Rhythm to be defibrillated Ventricular Tachycardia (VT, bpm >140)	600	Sensitivity > 75%	92%
Rhythm not to be defibrillated Normal sinus rhythm	1500	Specificity > 99%	100%
Rhythm not to be defibrillated Asystole	30	Specificity > 95%	100%
Non-treatable rhythm Generic AF, SVT, PVC	30	Specificity > 95%	100%
Positive predictive values			97.1%
False positives			4.1%

11.11 Defibrillator batteries

Category	Rated specifications
# (Model)	SMT-C14031
Type	non-rechargeable
Voltage/Capacity	12V@3000mAH
Performance *	<i>Standard 200J</i> 200 complete rescue cycles (shocks + CPR) at 200J. and Temp. 20°C Humidity 45% <i>ECG analysis</i> 36 continuous hours
Duration in Stand-by mode	Estimated 3 (three) years supposing a battery activation test and daily self-tests, without the AED being switched on (at environmental conditions of temperature 20°C and humidity 45% without condensation)

Category	Rated specifications
# (Model)	SMT-C14033
Type	non-rechargeable
Voltage/Capacity	12V@5600mAH
Performance *	<i>Standard 200J</i> 350 complete rescue cycles (shocks + CPR) at 200J. and Temp. 20°C Humidity 45%
	<i>ECG analysis</i> 100 continuous hours
Duration in Stand-by mode	Estimated 4 (four) years supposing a battery activation test and daily self-tests, without the AED being switched on (at environmental conditions of temperature 20°C and humidity 45% without condensation)

***Performance refers to new and fully charged battery stored at a constant temperature of 20°C and relative humidity of 45% without condensation**

11.12 Internal back-up battery

Category	Rated specifications
Type	Battery Coin Cell
Purpose	Preserving configuration data (date/time, etc.)
Voltage	3 VDC
Duration	Maintains date for 3 years (without external battery) Maintains date for 6 years (with external battery inserted within 12 months)

11.13 Defibrillation pads

Category	ADULT/CHILD
# (Models)	SMT-C2001 Pre-connected universal pads
	SMT-C2002 Face-to-face pre-connected universal pads
Packaging	Cable and connector external to the bag
Patient range	Adult age >8 years or weight > 25Kg Child age 1 - 8 years or weight < 25Kg
Intended use	Single-use
Number of shocks tolerated	50 shocks at 360J (please refer to the specific user manual)
Support material	Medical FOAM, thickness 1 mm
Conducting gel	Adhesive low-impedance conducting gel
Total surface (<i>per pad</i>)	136cm ²
Active area (<i>per pad</i>)	94 cm ²
Conducting material	Metal foil
Connection	Safety shock-proof connector
Cable length	120 cm (standard)

11.14 Timing of Shock cycles

Charge time performance in compliance with 60601-2-4 (201.101)	Maximum time	Compliance
The maximum time between the start of the ECG Analysis and the completion of maximum energy charge	< 30 seconds	√
The maximum time from when the AED is switched on until the completion of maximum energy charge	< 40 seconds	√

11.15 Hardware Requirements

Parameter	Functional Requirements
Defibrillator Module	<p>The defibrillator module shall have</p> <p>High Voltage Generator</p> <ul style="list-style-type: none"> The high voltage generator shall generate up to 1.8KV DC from a steady low voltage DC line. The High voltage transformer shall be driven by a N-Cannel Power MOSFET. The generator shall work in PWM mode. The high voltage generator shall have a current feedback system for primary and secondary side. Secondary side rectification by a half wave rectifier. <p>High Voltage Storage</p> <ul style="list-style-type: none"> The high voltage capacitor shall be a can type film Capacitor. <p>Bi-phasic Waveform Generator</p> <ul style="list-style-type: none"> The Bi-phasic waveform generator shall be with a bridge of IGBT's. The gate signals from the main controller shall be isolated. Dedicated Voltage regulator for the gate controller/Isolator. The whole circuit current shall be monitored. One high wattage current limiting resistor shall be in-between high voltage capacitor and the drive terminals. Free-wheeling diodes for each IGBT to suppress any back EMF. <p>Relay Circuits</p> <ul style="list-style-type: none"> When the device is turned ON, the patient leads (electrodes) to be connected to the ECG module. Whenever the patient in need of defibrillation then the patient leads to be switched to High voltage circuit. Two step switching is required to avoid back firing of ECG module by the high voltage circuit.
Power ON/OFF Switch	AED Power ON/OFF shall be a one touch operation
Indications on the selector switch	LED shall glow whenever the button needs to be pressed/acknowledgement while pressing the button
Defibrillator Battery	The device shall be with a primary source to power up

11.16 Cyber Security Safety applicability

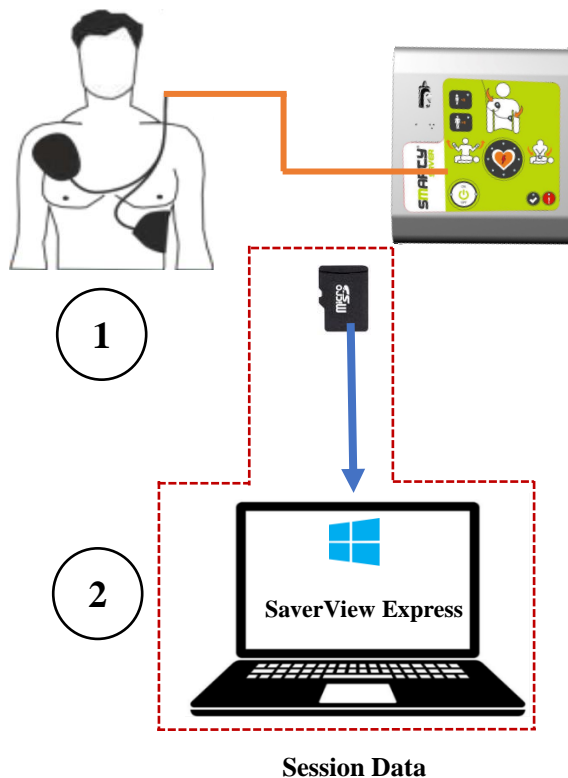

Cyber Security Applicability:

YES	NO
----------------	----

1. Patient Under Therapy
2. Session data display on Standalone computer

<u>Step-1</u> Patient Under Therapy	<ul style="list-style-type: none"> The device is designed to automatically detect and analyze the patient's heart rhythm, it is capable of delivering one or more defibrillation shocks if ventricular fibrillation or ventricular tachycardia (monomorphic or polymorphic with beat > 180) is detected. The energy is supplied by an exponential truncated biphasic electrical shock (B.T.E.) able to adapt to the patient's thoracic impedance. If an arrhythmia that requires a shock is detected the device will automatically deliver the defibrillation shock
<u>Step-2</u> Session data display on Standalone computer	<ul style="list-style-type: none"> Data recording and archiving is done automatically (cannot be deactivated by the user) both on the internal memory of the device and on the memory card when installed. Two types of files are stored on the external memory Card; AED1LOG.txt & AEDFILE.aed The rescue data recorded by the defibrillator can be stored, analyzed and printed from a Personal Computer using the management software SaverViewExpress.

11.17 Software Requirements

Programming Language	
Programming Language	C++ & C Programming
Development Environment / Debugging	IAR Linker, Compiler KEIL Linker, Compiler
Development Operating System	
	RTOS, ECOS

Note: The device records only session data by referring to the real time clock. No patient name or ID stored. User has to initiate storing the session data. The Data stored can be read only through SaverViewExpress Software & the file structure is a proprietary design of A.M.I. Italia S.r.l.
No other network required. Hence IT security & protection against unauthorized access is ensured.

12 Compliance with electromagnetic emission standards

The following paragraphs specify compliance with the electromagnetic emission standards:

- Guidelines and manufacturer declaration - Electromagnetic emissions
- Guidelines and manufacturer declaration - Electromagnetic immunity
- Recommended distances between portable and mobile radiofrequency communication equipment and the AED

12.1 Guidelines and manufacturer declaration – Electromagnetic emissions

SMARTY Saver was designed to be used in electromagnetic environments with the following characteristics.

Emissions test	Compliance	Electromagnetic environment - Guidelines
RF emissions CISPR 11	Group 1	The AED uses RF energy only for its internal operation. Its RF emissions are, therefore, very low and it is improbable that they may interfere with electronic devices nearby.
RF emissions CISPR 11	Class B	The AED can be used in any building, including residential buildings and buildings directly connected to the public low-voltage electricity network that supplies residential buildings.
Harmonic Emissions IEC 61000-3-2	Not applicable	
Voltage fluctuations/flickers IEC 61000-3-3	Not applicable	

12.2 Guidelines and manufacturer declaration - Electromagnetic immunity

SMARTY Saver was designed to be used in electromagnetic environments with the following characteristics.

Immunity test	Test level IEC/EN 60601-1	Compliance level	Electromagnetic environment Guidelines
Electrostatic discharge (ESD) IEC 61000-4-2	±6 kV contact	±6 kV contact	The floors must be made of wood, cement or ceramic bricks. If the floors are covered by synthetic materials, the relative humidity must be at least 30%
	±8 kV air	±8 kV air	
Fast transients/burst IEC 61000-4-4	±2 kV for electricity networks	Not applicable	
	±1 kV for I/O networks	±1 kV for I/O lines	
IEC 61000-4-11	< 5% U_T (> 95% dip in U_T) for 0.5 cycles 40% U_T (60% dip in U_T) for 5 cycles 70% U_T (30% dip in U_T) for 25 cycles < 5% U_T (>95% dip in U_T) for 5 seconds	Not applicable	

Immunity test	Test level IEC/EN 60601-1	Compliance level	Electromagnetic environment Guidelines
Supply frequency (magnetic field) 50/60 Hz IEC 61000-4-8	3 A/m	80 A/m	Power frequency magnetic fields must be at levels that do not exceed those of stations located in typical heavy industry applications, power plants and command rooms of high-voltage substations.
Note: U_T is the alternating network current before the application of the test level			
Conducted RF	3 Vrms	Not applicable	
IEC 61000-4-6	from 150 kHz to 80 MHz outside the ISM ^a bands 10 Vrms from 150 kHz to 80 MHz inside the ISM ^a bands	Not applicable	
Radiated RF IEC 61000-4-3	10 V/m from 80 MHz to 2.5 GHz	10 V/m	<p>The distance between portable and mobile RF communication devices in use and any part of the AED, including cables, must never be shorter than the recommended separation distance calculated based on the equation that applies to the transmitter's frequency.</p> <p>Recommended separation distance</p> $d = 1.2\sqrt{P} \text{ from 80 MHz to 800 MHz}$ $d = 2.3\sqrt{P} \text{ from 800 MHz to 2.5 GHz}$ <p>where P is the maximum output power of the transmitter in watt (W) in accordance with the data of the transmitter's manufacturer and is the recommended distance in metres (m)^b.</p> <p>The field strengths of fixed radiofrequency transmitters, as determined by an investigation in electromagnetic sites ^c, should be lower than the compliance level in all frequency ranges ^d.</p> <p>Interference may occur near devices marked with this symbol.</p> 
NOTE 1	The higher frequency interval applies at 80 MHz and 800 MHz		
NOTE 2	These guidelines may not apply to all situations. Electromagnetic propagation is affected by absorption and reflected from structures, objects and people		
a	The ISM (industrial, scientific and medical) bands between 150 kHz and 80 MHz are 6.765 MHz to 6.795 MHz; from 13.553 MHz to 13.567 MHz; from 26.957 MHz to 27.283 MHz; and from 40.66 to 40.70 MHz.		
b	The compliance levels in the ISM bands between 150 kHz and 80 MHz and between 80 MHz and 2.5		

	GHz are there to reduce the possibility of interference in case the portable and mobile communication devices are accidentally placed near the area where the patient is. For this reason, an additional factor of 10/3 is added to the calculation of the recommended separation distance for transmitters whose frequencies fall within these intervals.
c	It is not possible to predict with precision on a theoretical level the field strength of fixed transmitters, such as base stations for radiotelephones (mobile/cordless telephones) and wireless phones, amateur radios, AM and FM transmitters, and TVs. In order to assess the electromagnetic environment with fixed RF transmitters, please take into account the possibility of performing an electromagnetic analysis of the site. If the field strength measured at the site where the AED is used exceeds the specific RF compliance level as per above, it will be necessary to keep an eye on the AED, to check that it is working properly. If operating anomalies are observed, it may be necessary to adopt corrective actions, for example by moving or turning the AED.
d	Other than the frequency interval between 150 kHz and 80 MHz, the field strengths must be lower than 1 V/m.

12.3 Recommended separation distances between portable and mobile RF communication devices and the SMARTY Saver device

SMARTY Saver must be used in an electromagnetic environment in which interference from radiated RF is controlled. The customer or operator of **SMARTY Saver** can help prevent electromagnetic interference by maintaining the minimum distances between portable and mobile RF communication devices (transmitters) and **SMARTY Saver** recommended below, based on the maximum output power of the communication devices.

Maximum Rate of transmitter power emission (W)	Separation distance in accordance with the transmitter's frequency (m)			
	From 150kHz to 80 MHz outside the ISM bands	From 150kHz to 80 MHz inside the ISM bands	From 80 MHz to 800 MHz	From 800 MHz to 2.5 Hz
	$d = 1.2\sqrt{P}$	$d = 1.2\sqrt{P}$	$d = 1.2\sqrt{P}$	$d = 2.3\sqrt{P}$
0.01	0.12 m	0.12 m	0.12 m	0.23 m
0.1	0.37 m	0.38 m	0.38 m	0.73 m
1	1.12 m	1.2 m	1.2 m	2.3 m
10	3.7 m	3.8 m	3.8 m	7.3 m
100	12 m	12 m	12 m	23 m
For transmitters whose estimated maximum power is not listed above, the separation distance "d" in metres (m) can be determined using the equation that applies to the transmitter's frequency, where P represents the maximum power produced by the transmitter in watt (W) in accordance with the transmitter's manufacturer.				
NOTE 1:	At 80 MHz and 800 MHz, the separation distance applied is the one used for high frequency intervals.			
NOTE 2:	The ISM frequency bands (for industrial, scientific and medical application) between 150 kHz and 80 MHz are 6.765 MHz to 6.795 MHz; 13.553 MHz to 13.567 MHz; 26.957 MHz to 27.283 MHz and 40.66 MHz to 40.70 MHz			







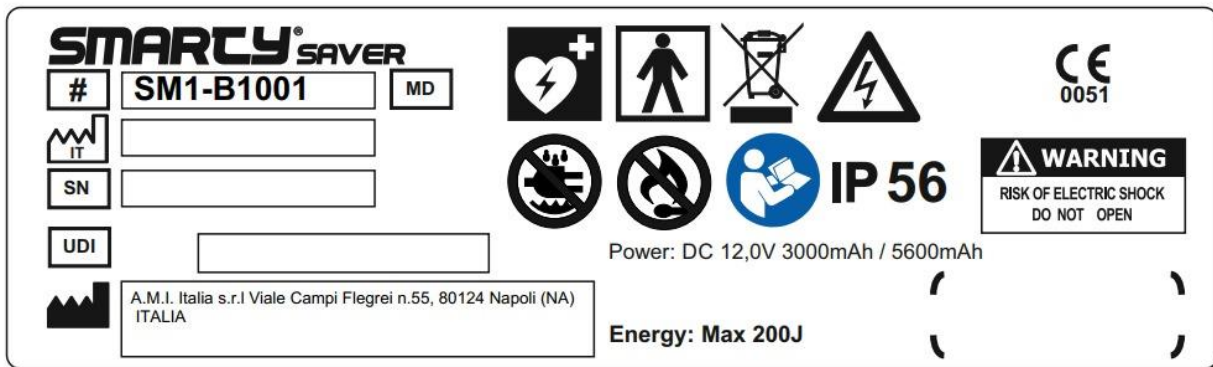



NOTE 3:	An additional factor of 10/3 is used in the calculation of the recommended separation distance for transmitters in the ISM frequency bands between 150 kHz and 80 MHz and in the frequency interval from 80 MHz to 2.5 GHz to reduce the possibility that portable/mobile equipment can interfere, if accidentally brought into the patient's area.
NOTE 4:	These guidelines may not be applicable to all situations. Electromagnetic diffusion is affected by absorption and reflected from structures, objects and people.









13 Symbols

Product Label:

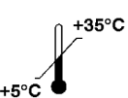

	High Electrical Voltage		"CE" is the abbreviation of "conformité européenne", which is the European conformity as per MDR 2017/745 for Medical Devices. 0051 is the Notified body number for IMQ ISTITUTO ITALIANO DEL MARCHIO DI QUALITÀ S.P.A.
	General Warnings: Please refer to the accompanying documents before using the device	IP56	Level of Protection of the device against dust and water (including the battery)
	Type BF, Defibrillation-proof device	SN	Serial Number
	Do not expose to high temperatures or flames		Country and Date of Manufacture
	Do not recharge	LOT	Lot Number (LOT)
	Do Not Open		Expiry Date
	Do not destroy or damage	#	Model identifier
	Do not use in water puddles		Manufacturer Name

	Read the User Manual
	Battery Recycling
	Please comply with the local regulatory framework on waste
	Fragile
	Keep in a dry place
	Do not expose to direct sunlight
	Shock hazard do not open
	Do not use if package is damaged
	Universal ILCOR symbols for AEDs
	Medical Device

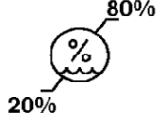
	Latex-Free
	Single-use, do not reuse
	Non-Sterile
	This Side Up
	Temperature Limits
	Do not stack in piles of more than 6 boxes
	Unique Device Identification
	Consult instructions for use
	Humidity Limits

14 SMARTY Saver Series defibrillator warranty

1 Restriction of the Warranty

A.M.I. Italia S.r.l. guarantees original buyers that its *SMARTY Saver* series defibrillators and the related accessories and batteries are free of all material and manufacture defects, in accordance with the terms and conditions of this limited warranty. The original buyer shall be considered to be the end user of the product purchased. This limited warranty is granted solely to the original buyer of the *SMARTY Saver* defibrillator and may not be leased or assigned to third parties.

The *SMARTY Saver* Series defibrillators are as follows:

- **SMARTY SaverTech** semi-automatic or automatic (# **SMB-B0001** or **SMA-B0002**)
- **SMARTY Saver** semi-automatic or automatic (# **SM1-B1001** or **SM2-B1002**)
- **SMARTY SaverPlus** semi-automatic or automatic (#**SM3-B1003** or **SM4-B1004**)
- **SMARTY SaverGeo** semi-automatic or automatic (# **SM5-B1005** or **SM6-B1006**)

2 Term

The warranty offered by A.M.I. Italia S.r.l. has the following term (starting from the date of purchase):

- **SMARTY Saver Series AED:** Five (5) years
- **Non-rechargeable batteries:** Three (3) years (in Stand-by mode, supposing a battery activation test, daily self-tests, without the AED being switched on and under the environmental conditions of temperature at 20°C and humidity 45% without condensation)
- **Single-use PADs:** until the expiry date indicated on the packaging.
- **All other accessories** shall be under warranty for one (1) year.

3 Procedure for the activation of the warranty

The user is required to register the device in the dedicated section of the website of A.M.I. italia S.R.L. www.amitalia.com.

If a defect covered by this warranty is found, the original buyer must activate the Return Material Authorisation (RMA) procedure through the dedicated section on the website www.amitalia.com. The repaired or replaced product will be guaranteed - for the specific defect - for one (1) year, while the terms and conditions of this Warranty shall apply to all other parts that were not subjected to the repair service.

4 Exclusions

This warranty shall not cover instances of non-compliance subsequently to the purchase, such as those caused by accidents, modifications, improper or

abusive use, non-compliance with the procedures or hazards or warnings or cautions described in the user manual, failure to perform reasonable and adequate maintenance, incorrect installation, replacement of parts and accessories that does not comply with the specifications provided by A.M.I. Italia S.r.l., any modifications to the device, and, in general, all subsequent instances of non-compliance deriving from failure to comply with the requirements contained in the user manual.

This warranty shall not cover - as it does not constitute a case of original non-conformity - the normal wear and tear of components subject to degradation during use, such as Buttons, LEDs and battery contacts. Furthermore, this warranty will be automatically declared invalid in one of the following cases:

- the serial number of the *SMARTY Saver* AED is modified, erased, rendered illegible or, in any case, tampered with
- the warranty seal placed on the *SMARTY Saver* AED is removed (the device is opened)
- the commercial name of the product or of the manufacturer is covered, modified or erased

Lastly, this warranty shall not be valid for the *SMARTY Saver* AEDs that were sold used; in such case, the warranty must be offered by the reseller of the used product with exclusion of all liability, also indirect, of A.M.I. Italia S.r.l..

5 Damage

Unless expressly laid down by this warranty. A.M.I. Italia S.r.l. WILL NOT BE LIABLE FOR ANY INCIDENTAL OR INDIRECT DAMAGE DERIVING FROM THE USE OF THE *SMARTY Saver* SERIES DEFIBRILLATOR OR CLAIMS BY VIRTUE OF THIS AGREEMENT, WHETHER THE CLAIM REFERS TO THIS CONTRACT, TO AN OFFENCE OR OTHER. The warranty declarations mentioned shall be exclusive and shall prevail over almost all other remedies. Certain countries do not allow the exclusion or limitation of incidental and indirect damage, for which the aforementioned limitation or exclusion may not apply.

6 Waiver

ANY IMPLICIT GUARANTEES PERTAINING TO MARKETABILITY OR SUITABILITY FOR A SPECIFIC USE AND ALL IMPLICIT GUARANTEES DERIVING FROM NEGOTIATIONS, COMMERCIAL USE OR HABITS, STATUTORY OR OTHER, SHALL BE STRICTLY LIMITED TO THE TERMS OF THIS

WRITTEN WARRANTY. This warranty will constitute the sole and exclusive remedy of the buyer in relation to this purchase. In case of a presumed violation of any warranty or legal action by the original buyer for presumed negligence or other unlawful behaviour by A.M.I. Italia S.r.l, the sole and exclusive remedy of the original buyer will consist in the repair or replacement of the materials found to be defective, based on what has been laid down previously. No reseller or agent or employee of A.M.I. Italia S.r.l. shall be authorised to amend, extend or expand this warranty.

7 Territorial limits

This warranty shall be valid for products purchased in one of the Countries of the European Union or in countries where the rules and laws of the EU apply.

8 Warning

Install, use and perform maintenance on the *SMARTY Saver* defibrillators of A.M.I. Italia S.r.l. in strict compliance with the instructions contained in the user manual

9 Other rights

This limited warranty guarantees specific legal rights to the original buyer; any other rights may vary depending on the country where they live.

10 Jurisdiction

Any dispute relating to this agreement or arising from the use of the *SMARTY Saver* series defibrillators of A.M.I. Italia S.r.l. will be governed by Italian law, before the Courts of Naples, Italy

15 Declaration of Medical Substances

By design, this *SMARTY Saver* defibrillator does not incorporate any medicinal substances.

16 Additional Information

- All operations for this device are mentioned in this user manual. No special operating instructions required for the intended use of this device.
- The device service life is 10 years.
- Inform the dealer/manufacturer if the labels on the device peeled off.
- Only defibrillator PADs which come in direct contact with the patient. So these are classified as Type BF applied part.
- Software updates to be performed only by the manufacturer's authorized representative

16.1 Incident Reporting

If the user or patient needs to report any serious incidents in relation to the device, can contact the manufacturer and the competent authority of the Member State where the user and / or patient is established.

16.2 Information Available to The User

The user manual is provided with the device in a paper format additionally, electronic copy is available on the company weblink: <http://www.amiitalia.com>

16.3 Availability of SSCP

SSCP will be made available on EUDAMED once the EUDAMED is completely functional.

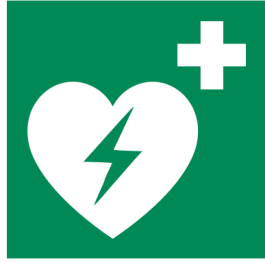

SMARTCY[®] **SAVER**

